

Approved Code of Practice For
**LOAD-LIFTING
RIGGING**

Published by the Occupational Safety and Health Service,
Department of Labour, Wellington, New Zealand.

First edition 1974

Revised 1979

Revised 1983

Reprinted 1989

Reprinted 1990

Revised 2001

ISBN 0-477-03595-7

Contents

Notice of Issue	5
Foreword	6
A Summary of the Health and Safety in Employment Act 1992	7
Regulations	7
Approved Codes of Practice	7
Employers' Duties	7
Hazard Management	8
Information for Employees	9
Employers to Involve Employees in the Development of Health and Safety Procedures	9
Training of Employees	9
Duties of Self-Employed People, Principals and Employees	10
Accidents and Serious Harm (Records and Notification)	10
Health and Safety in Employment Regulations	11
Part 1: Scope and General	12
1.1 Introduction	12
1.2 Scope	12
1.3 Definitions	12
Part 2: General Safety and Equipment	16
2.1 General	16
2.2 Safety Systems	16
2.3 Personal Safety	16
2.4 Tools and Equipment	17
Part 3: Equipment and Appropriate Safety Factors	18
3.1 Identification	18
3.2 Factor of Safety	18
3.3 Flat Web and Round Slings	19
3.4 Chain and Chain Slings	22
3.5 Wire Rope	26
3.6 Components	26
Part 4: Rope Splices	29
4.1 Fibre Ropes	29
4.2 Wire Rope	29
4.3 Wire Rope Thimbles	30
4.4 Wire Rope (Bulldog) Grips	30
Part 5: Fittings, Sheaves and Blocks	33
5.1 Wedge-Type Rope Sockets	33
5.2 Rings	33
5.3 Shackles	33

5.4	Rigging Screws and Turnbuckles	36
5.5	Snatch, Sheave and Cargo Blocks	37
5.6	Lifting Beams, Spreaders and Frames	38
5.7	Eyebolts for Lifting	39
5.8	Chainblocks	39
5.9	Lever Hoists	40
5.10	Hooks	40
5.11	Other General Gear	40
5.12	Inspection	40
5.13	Register	40
Part 6:	Rigging for Crane Work and Building Construction	43
6.1	Evaluating the Load	43
6.2	Load Estimation — Weight and Centre of Gravity	43
6.3	Volumes of Common Shapes	45
6.4	Load Security — Balance and Stability	46
6.5	Structures	47
6.6	Packing	47
6.7	Slings	49
6.8	Winches, Sheaves and Purchases for Flexible Steel Wire Rope	66
6.9	Rigging Blocks	76
6.10	Handling Steel Plate	79
6.11	Mobile Cranes On Site Concrete Tilt Slab (Panel) Erection	80
6.12	On Site Concrete Tilt Slab (Panel) Erection	83
Appendix:	Reference Documents	84

Notice of Issue

I have issued this *Approved Code of Practice for Load-Lifting Rigging*, being a statement of preferred work practices or arrangements for the purpose of ensuring the health and safety of persons to which this code applies and persons who may be affected by the activities covered by this code.

A handwritten signature in black ink, appearing to read 'J M Chetwin', written over a horizontal line.

J M Chetwin
Secretary of Labour

Foreword

I have approved this statement of preferred work practices, which is an *Approved Code of Practice for Load-Lifting Rigging*, under section 20 of the Health and Safety in Employment Act 1992. When a code is approved, a Court may have regard to it in relation to compliance with the relevant sections of the Health and Safety in Employment Act. This means that if an employer in an industry or using a process to which an approved code applies can show compliance with that code in all matters it covers, a Court may consider this to be compliance with the provisions of the Act to which the code relates.



Hon. Margaret Wilson
Minister of Labour

A Summary of the Health and Safety in Employment Act 1992

The principal object of the Health and Safety in Employment Act 1992 (HSE Act) is to prevent harm to employees at work. To do this, it imposes duties on employers, employees, principals and others, and promotes excellent health and safety management by employers. It also provides for the making of regulations and codes of practice.

Regulations

Regulations are promulgated from time to time under the HSE Act. Regulations may, among other things, impose duties on employers, employees, designers, manufacturers, and others relating to health and safety. These regulations may apply with respect to places of work, plant, processes or substances and may deal with particular problems that have arisen.

Approved Codes of Practice

“Approved Codes of Practice” are provided for in the HSE Act. They are statements of preferred work practice or arrangements, and may include procedures which could be taken into account when deciding on the practicable steps to be taken. Compliance with codes of practice is not mandatory. However, they may be used as evidence of good practice in Court.

Employers’ Duties

Employers have the most duties to ensure the health and safety of employees.

Employers have a general duty to take all practicable steps to ensure the safety of employees while at work. In particular, they are required to take all practicable steps to:

- (a) Provide and maintain a safe working environment;
- (b) Provide and maintain facilities for the safety and health of employees at work;

- (c) Ensure that machinery and equipment is safe for employees;
- (d) Ensure that working arrangements are not hazardous to employees; and
- (e) Provide procedures to deal with emergencies that may arise while employees are at work.

Taking “all practicable steps” means doing what is reasonably able to be done in the circumstances, taking into account:

- (a) The severity of any injury or harm to health that may occur;
- (b) The degree of risk or probability of that injury or harm occurring;
- (c) How much is known about the hazard and the ways of eliminating, reducing or controlling it; and
- (d) The availability, effectiveness and cost of the possible safeguards.

Hazard Management

Employers must identify and regularly review hazards in the place of work (existing, new and potential), to determine whether they are significant hazards and require further action. If an accident or harm occurs that requires particulars to be recorded, employers are required to investigate it to determine if it was caused by or arose from a significant hazard.

“Significant hazard” means a hazard that is an actual or potential cause or source of:

- (a) Serious harm; or
- (b) Harm (being more than trivial) where the severity of effects on any person depend (entirely or among other things) on the extent or frequency of the person’s exposure to the hazard; or
- (c) Harm that does not usually occur, or usually is not easily detectable, until a significant time after exposure to the hazard.

Where the hazard is significant, the HSE Act sets out the steps employers must take:

- (a) Where practicable, the hazard must be eliminated.
- (b) If elimination is not practicable, the hazard must be isolated.
- (c) If it is impracticable to eliminate or isolate the hazard completely, then employers must minimise the likelihood that employees will be harmed by the hazard.

Where the hazard has not been eliminated or isolated, employers must, where appropriate:

- (a) Ensure that protective clothing and equipment is provided, accessible and used;
- (b) Monitor employees' exposure to the hazard;
- (c) Seek the consent of employees to monitor their health; and
- (d) With informed consent, monitor employees' health.

Information for Employees

Before employees begin work, they must be informed by their employer of:

- (a) Hazards employees may be exposed to while at work;
- (b) Hazards employees may create which could harm other people;
- (c) How to minimise the likelihood of these hazards becoming a source of harm to themselves and others;
- (d) The location and correct use of safety equipment;
- (e) Emergency procedures.

Employers are also required to inform employees of the results of any health and safety monitoring. In doing so, the privacy of individual employees must be protected.

Employers to Involve Employees in the Development of Health and Safety Procedures

Employers need to ensure that all employees have the opportunity to be fully involved in the development of procedures for the purpose of identifying hazards and dealing with significant hazards, or dealing with or reacting to emergencies and imminent dangers.

Training of Employees

The following is an excerpt from the Act:

“Training and supervision—Every employer shall take all practicable steps to ensure that every employee who does work of any kind, or uses plant of any kind, or deals with a substance of any kind, in a place of work—

- (a) Either—
 - (i) Has; or
 - (ii) Is so supervised, by a person who has,—such knowledge and experience of a similar place, and work, plant, or substances of that kind, as to ensure that the employee's doing the work, using the plant, or dealing with

the substance, is not likely to cause harm to the employee or other people; and

- (b) Is adequately trained in the safe use of all plant, objects, substances, and protective clothing and equipment that the employee is or may be required to use or handle.”

Duties of Self-Employed People, Principals and Employees

The following is an excerpt from the Act:

17. Duties of self-employed people—Every self-employed person shall take all practicable steps to ensure that no action or inaction of the self-employed person while at work harms the self-employed person or any other person.

18. Duties of principals—(1) Every principal shall take all practicable steps to ensure that—

- (a) No employee of a contractor or subcontractor; and

- (b) If an individual, no contractor or subcontractor—

is harmed while doing any work (other than residential work) that the contractor was engaged to do.

- (2) Subsection (1) of this section shall be read subject to section 2(2) of this Act.

19. Duties of employees—Every employee shall take all practicable steps to ensure—

- (a) The employee’s safety while at work; and

- (b) That no action or inaction of the employee while at work causes harm to any other person.”

Accidents and Serious Harm (Records and Notification)

The HSE Act requires employers to keep a register of work-related accidents and serious harm. This includes every accident that harmed (or might have harmed):

- (a) Any employee at work;

- (b) Any person in a place of work under the employer’s control.

Employers are also required to investigate all accidents, harm and near misses to determine whether they were caused by a significant hazard.

Employers are required to notify serious harm that occurs to employees while at work to the Secretary (in practice, the nearest OSH office), as soon as possible. In addition, the accident must also

be reported on the prescribed form within 7 days. (Forms are included in the Workplace Accident Register, available from OSH offices and selected stationers.)

If a person suffers serious harm, the scene of the accident must not be disturbed unless to:

- (a) Save life or prevent suffering;
- (b) Maintain public access for essential services, e.g. electricity, gas;
- (c) Prevent serious damage or loss of property.

The OSH office will advise whether it wishes to investigate the accident and what action may be taken in the meantime.

Health and Safety in Employment Regulations

The Health and Safety in Employment Regulations 1995 extend the provisions of section 6 of the Act in relation to the provision of facilities such as toilets, first aid, and washing of hands and body, and the provision of wholesome and sufficient drinking water.

The regulations also place duties on employers in relation to specific hazards. In respect of rigging work, the most relevant regulation (regulation 21) covers work at heights of over 3 metres. This regulation requires employers to take all practicable steps to ensure that, where any employee may fall more than 3 metres, then:

- (a) Means are provided to prevent the employee from falling; and
- (b) Any means so provided are suitable for the purpose for which they are to be used.

Other regulations that would impact on riggers include those for scaffolding (regulation 22), notifiable work (regulation 26), and working under raised objects (regulation 16).

PART 1: SCOPE AND GENERAL

1.1 INTRODUCTION

This approved code of practice has been prepared to assist in realising the aim of better provision for safety by providing recommendations and procedures for safe practice while carrying out lifting and rigging work in industry.

1.2 SCOPE

This code applies to all places of work at which an employee has to use lifting and rigging practices in the course of their duties.

1.3 DEFINITIONS

Competent person: A person who has acquired, through a combination of qualifications, training or experience, the knowledge and skill to perform the task required.

Construction work: (a) Means any work in connection with the alteration, cleaning, construction, demolition, dismantling, erection, installation, maintenance, painting, removal, renewal, or repair of—

- (i) Any building, chimney, edifice, erection, fence, structure, or wall, whether constructed wholly above or below, or partly above and partly below, ground level:
- (ii) Any aerodrome, cableway, canal, harbour works, motorway, railway, road, or tramway:
- (iii) Any thing having the purpose of drainage, flood control, irrigation or river control:
- (iv) Any distribution system or network having the purpose of carrying electricity, gas, telecommunications, or water:
- (v) Any aqueduct, bridge, culvert, dam, earthwork, pipeline, reclamation, reservoir or viaduct:
- (vi) Any scaffolding.

Employee: Means person employed by any other person to do any

(Visual inspection should be carried out prior to and during use at all times.)

work (other than residential work) for hire or reward; and in relation to any employer, means an employee of the employer.

Employer: A person who or that employs any other person to do any work for hire or reward, and, in relation to any employee, means an employer of the employee.

Fall-arrest device (self-locking anchorage): A self-locking device whose function is to arrest a fall.

Fall-arrest harness: An assembly of interconnected shoulder and leg straps, with or without a body belt, designed for attachment to a lanyard, pole strap, or fall-arrest device as specified in AS/NZS 1891:1995 and used where there is a likelihood of free or unrestrained fall.

FSWR: Flexible steel wire rope.

Grommet: Endless wire rope sling.

Lifting appliance: Means any appliance (except where defined in the *Approved Code of Practice for Cranes*) capable of being operated by mechanical, manual, or other means to raise or lower a load in a vertical or near vertical plane, and includes any lifting tackle.

Lifting beams: Is a beam which carries loads from two or more points while being supported by one or more different points.

Lifting frame: Is a device made up of more than one lifting beam.

Lifting spreader: Is a device which spreads the lifting ropes and is in compression. Refer to page 37.

Lifting tackle: Means any sling, shackle, swivel, ring, hook or other appliances, including lifting beams, frames and spreaders, used in connection with a lifting appliance or from the hook of a crane.

MBL: Minimum breaking load of the lifting tackle.

Mechanical splice: An alloy, copper or steel sleeve fitting pressed onto wire, generally to form an eye in the wire.

Notifiable work: Means—

- (a) Any restricted work, as that term is defined in regulation 2(1) of the Health and Safety in Employment (Asbestos) Regulations 1998:
- (b) Any logging operation or tree-felling operation, being an operation that is undertaken for commercial purposes:
- (c) Any construction work of one or more of the following kinds:
 - (i) Work in which a risk arises that any person may fall 5 metres or more, other than—
 - (A) Work in connection with a residential building up to and including 2 full storeys:

(Visual inspection should be carried out prior to and during use at all times.)

- (B) Work on overhead telecommunications lines and overhead electric power lines:
- (C) Work carried out from a ladder only:
- (D) Maintenance and repair work of a minor or routine nature:
 - (ii) The erection or dismantling of scaffolding from which any person may fall 5 metres or more:
 - (iii) Work using a lifting appliance where the appliance has to lift a mass of 500 kilograms or more a vertical distance of 5 metres or more, other than work using an excavator, a forklift, or a self-propelled mobile crane:
 - (iv) Work in any pit, shaft, trench, or other excavation in which any person is required to work in a space more than 1.5 metres deep and having a depth greater than the horizontal width at the top:
 - (v) Work in any drive, excavation, or heading in which any person is required to work with a ground cover overhead:
 - (vi) Work in any excavation in which any face has a vertical height of more than 5 metres and an average slope steeper than a ratio of 1 horizontal to 2 vertical:
 - (vii) Work in which any explosive is used or in which any explosive is kept on the site for the purpose of being used:
 - (viii) Work in which any person breathes air that is or has been compressed or a respiratory medium other than air.

Operator: A person who operates any plant or equipment.

Reeving: To place the rope or webbing sling through a block or eye.

Restraint belt: A body belt designed for attachment to a restraint line and not designed for free fall or restrained fall.

Restraint line: A line used to restrict the horizontal movement of the wearer and not designed for either free fall or restrained free fall.

Rigger/Dogger: A person who has been instructed in the proper selection of slings and the slinging of loads, and who understands the capabilities of the crane with which he is working. A dogger is competent to carry out elementary slinging or lifting tasks and the directing and positioning of loads.

Rigging: The use of mechanical load-shifting equipment and associated gear to move, place or secure a load including plant, equipment, or members of a building or structure and to ensure the stability of those members, and for the setting up and dismantling of

(Visual inspection should be carried out prior to and during use at all times.)

cranes and hoists, other than the setting up of a crane or hoist which only requires the positioning of external outriggers or stabilisers.

Snotter: Means a rope strop with an eye spliced in both ends.

Standards: Standards are quoted throughout this code of practice, but another standard may be acceptable if proved to be equivalent. Standards are used not as a restriction but as a means of compliance with the code of practice.

SWL: Safe working load.

Tag line: A rope of suitable strength, construction and length attached with an appropriate recognised bend or hitch to the load, used to control the load during lifting or positioning.

Test certificate: A certificate issued by an authorised person or authority.

WLL: Working load limit. Normally relates to SWL and is the same, however, refer to manufacturers' specifications.

(Visual inspection should be carried out prior to and during use at all times.)

PART 2: GENERAL SAFETY AND EQUIPMENT

2.1 GENERAL

2.1.1 Lifting and rigging often needs to be carried out at a height where danger from falling is greater than normal.

2.2 SAFETY SYSTEMS

2.2.1 A safety system could include either one or a combination of the following devices:

- (a) Anchors and inserts;
- (b) Harnesses and belts;
- (c) Ropes and slings;
- (d) Lanyards and shock absorbers;
- (e) Inertia reels (retractable lifelines);
- (f) Barricades or guardrails;
- (g) Tensioning devices;
- (h) Safety nets.

2.3 PERSONAL SAFETY

2.3.1 Personal protective equipment includes the following:

- (a) Hard hat and safety shoes or boots to approved Standard;
- (b) Close-fitting overalls or clothes and close-fitting leather gloves;
- (c) Ear and eye protection;
- (d) Fall protection equipment as appropriate;
- (e) Wet weather clothing;
- (f) Specialist equipment to suit the job at hand;
- (g) Ultraviolet protection:
 - Sunscreen;

(Visual inspection should be carried out prior to and during use at all times.)

- Hat;
- Suitable clothing;
- (h) Respiratory protection.

2.4 TOOLS AND EQUIPMENT

- 2.4.1 When climbing and working at heights the number of tools and items of equipment carried should be minimal and the use of a lanyard on tools is recommended.

(Visual inspection should be carried out prior to and during use at all times.)

PART 3: EQUIPMENT AND APPROPRIATE SAFETY FACTORS

3.1 IDENTIFICATION

- 3.1.1 Every lifting appliance and item of loose gear shall be clearly and permanently marked with its SWL by stamping, or where this is impracticable, by other suitable means. Also, a unique identifying number to clearly identify individual items.

3.2 FACTOR OF SAFETY

- 3.2.1 The factor of safety is the ratio between the minimum breaking load and the safe working load.
- 3.2.2 The factor of safety for the following equipment must not be less than 6:1:
- (a) Web slings;
 - (b) Round slings;
 - (c) Shackles.
- 3.2.3 The factor of safety for steel wire rope must not be less than 5:1. For special-purpose ropes, check on manufacturer's specifications.
- 3.2.4 The factor of safety for chain and associated hardware must not be less than four (4), and the chain for slings shall be to a suitable ISO Standard or equivalent grade endorsed for lifting purposes. All chains and fittings should be of the same grade and not be mixed. Grade 80 and Grade 8 are considered to be compatible.
- Note: If a higher grade chain or component is used in a sling assembly, the sling must be rated to the lowest SWL of the chain or components being used.**
- Only grades of chain complying with EN818 or equivalent can be used with lifting.
- 3.2.5 For all other grades above Grade 80, e.g. Grade 85, Grade 95, etc., refer to manufacturers' working load limit charts.
- 3.2.6 The factor of safety for fibre ropes varies depending on the diameter and must be as per BS 6668 or charts on pages 22 and 23.

(Visual inspection should be carried out prior to and during use at all times.)

3.3 FLAT WEB AND ROUND SLINGS

- 3.3.1 Webbing slings are manufactured to comply with NZS 5227 or equivalent. All slings have a minimum 6:1 safety factor.
- 3.3.2 The figures on pages 19 and 20 illustrate six basic sling types, with a minimum safe working load (SWL) 6:1 safety factor. The SWL (see table) is quoted in kilograms for vertical, choker, or basket application, in single or two-ply construction.
- 3.3.3 Round slings comprise a hank of polyester yarn of one or more strands wound together continuously to form an endless sling protected by an outer sleeve.
- 3.3.4 The slings have woven stripes in the outer casing, each of which represents 1 tonne safe working load. They may also be colour coded.

The combination of woven stripes with recognised colour codes enables the user to more easily recognise the capacity of the sling even when it is soiled.

- 3.3.5 Care should be taken when inspecting web slings utilising wear sleeves and particularly in the case where the full length of the sling is not visible.

Webbing sling should be inspected for:

- (a) Cuts or damage to webbing;
- (b) Damage to eyes;
- (c) Damage to metal eyes or other end fittings; and
- (d) Chemical damage.

THE SIX BASIC PATTERNS OF FLAT WEB SLINGS



Flat eye



Reversed eye

1. Flat eye slings for vertical or basket hitches.
2. Reversed eye slings for choker hitches or where proper alignment of the load is needed—the eyes being in the same plane as the webbing.

(Visual inspection should be carried out prior to and during use at all times.)

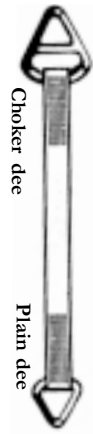

Metal dee



Endless

3. Same application but with metal dees. These dees can be plain both ends or in choker form.
4. Loop slings – most suitable for bulky and awkward loads where stability and easy contour are most important factors.



Cradle sling

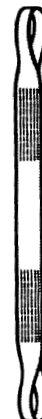

Reduced eye

5. Wide load loop slings – an extension of the sling. The use of the wide load pad gives greatest possible bearing surface for delicate loads.
6. Reduced eye slings for use with small hooks.

(Visual inspection should be carried out prior to and during use at all times.)

TABLE 1: WEB SLINGS - SAFE WORKING CAPACITY (SWL 6:1 CAPACITY RATINGS IN TONNES)







Nominal Sling Width	No. of Plies	Single-Leg Sling				Endless Sling			
									
38 mm	One	0.75	0.60	1.05	1.50	1.50	1.20	2.10	3.00
	Two	1.50	1.20	2.10	3.00	3.00	2.40	4.20	6.00
50 mm	One	1.00	0.80	1.40	2.00	2.00	1.60	2.80	4.00
	Two	2.00	1.60	2.80	4.00	4.00	3.20	5.60	8.00
75 mm	One	1.50	1.20	2.10	3.00	3.00	2.40	4.20	6.00
	Two	3.00	2.40	4.20	6.00	6.00	4.80	8.40	12.00
100 mm	One	2.00	1.60	2.80	4.00	4.00	3.20	5.60	8.00
	Two	4.00	3.20	5.60	8.00	8.00	6.40	11.20	16.00
150 mm	One	3.00	2.40	4.20	6.00	6.00	4.80	8.40	12.00
	Two	6.00	4.80	8.40	12.00	12.00	9.60	16.80	24.00
200 mm	One	4.00	3.20	5.60	8.00	8.00	6.40	11.20	16.00
	Two	8.00	6.40	11.20	16.00	16.00	12.80	22.40	32.00
300 mm	One	6.00	4.80	8.40	12.00				
	Two	12.00	9.60	16.80	24.00				

TABLE 2: COLOUR CODING AND LIFTING CAPACITY OF SYNTHETIC SLINGS (IN TONNES)

Colour	Tonnes			
	Vertical	Choke	Basket	90° Basket
Violet	1.0	0.80	1.40	2.0
Green	2.0	1.60	2.80	4.0
Yellow	3.0	2.40	4.20	6.0
Orange*	4.0	3.20	5.60	8.0
Red	5.0	4.00	7.00	10.0
Brown	6.0	4.80	8.40	12.0
Blue	8.0	6.40	11.20	16.0
Grey*	12.0	9.60	16.80	24.0

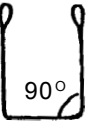
Note: Other colours may be accepted with supporting certificates.

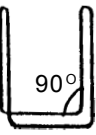

* From Europe, grey is rated 4 tonnes and orange is rated 12 tonnes for vertical lifts.

* From Australia, grey is rated 4 tonnes and orange is rated 10 tonnes for vertical lifts.

(Visual inspection should be carried out prior to and during use at all times.)

MANILA ROPE

TABLE 3: MAXIMUM SAFE WORKING LOADS FOR SLINGS IN THREE-STRAND HAWSER LAID CONSTRUCTIONS FOR ENDLESS SLING CONFIGURATIONS

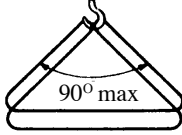
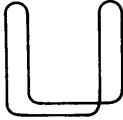
Nominal diameter of rope (three strand hawser laid)	Maximum safe working load (Note: "M" = Mode Factor)			
	Straight pull M = 2.0	Choke hitch M = 1.6	Basket hitch M = 2.8	Basket hitch parallel M = 4.0
				
mm	t	t	t	t
12	0.250	0.200	0.350	0.500
14	0.350	0.280	0.490	0.700
16	0.550	0.440	0.770	1.1
18	0.700	0.560	0.980	1.4
20	0.976	0.781	1.4	2.0
24	1.5	1.2	2.1	3.1
28	2.2	1.8	3.1	4.4
32	3.0	2.4	4.2	6.0
36	3.8	3.0	5.3	7.6
40	5.0	4.0	7.0	10.0
44	6.0	4.8	8.4	12.0
48	7.6	6.1	10.6	15.2

Note: Slings having working loads below 1 tonne are usually marked in kilograms.
1 tonne = 1000 kilograms.

3.4 CHAIN AND CHAIN SLINGS

- 3.4.1 Refer to BS 4942 or equivalent for chain and ISO 7593 or equivalent for chain slings and to the following charts on pages 24 and 25.
- 3.4.2 Safety factor of 4:1.
- 3.4.3 Chain slings should be inspected for:
 - (a) Corrosion;
 - (b) Worn, stretched or deformed links;
 - (c) Worn, stretched or deformed hooks and fittings; and
 - (d) Wear on load pins and to ensure retainers installed correctly.

(Visual inspection should be carried out prior to and during use at all times.)

TABLE 4: MAXIMUM SAFE WORKING LOADS FOR SLINGS MADE OF GRADE 1 MANILA ROPES IN THREE-STRAND HAWSER LAID CONSTRUCTIONS FOR SINGLE STROP CONFIGURATIONS

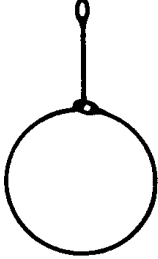
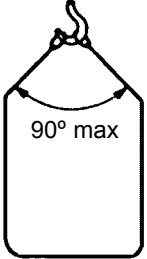
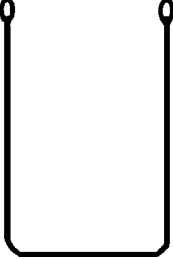
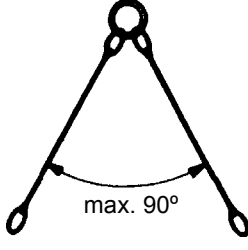
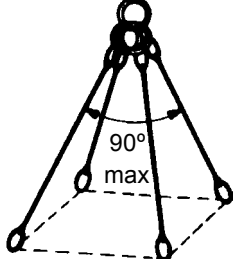
Nominal diameter of rope (three-strand hawser laid)	Maximum safe working load					
	Straight pull M = 1.0 	Choke hitch M = 0.8 	Basket hitch max. 90° M = 1.4 	Basket hitch parallel M = 2.0 	Two-legged M = 1.4 	Four-legged M = 1.4 
mm	t	t	t	t	t	t
12	0.125	0.100	0.175	0.250	0.175	0.250
14	0.175	0.140	0.245	0.350	0.245	0.350
16	0.275	0.220	0.385	0.550	0.385	0.550
18	0.350	0.280	0.490	0.700	0.490	0.700
20	0.488	0.390	0.683	0.976	0.683	0.976
24	0.763	0.610	1.1	1.5	1.1	1.5
28	1.1	0.880	1.5	2.2	1.5	2.2
32	1.5	1.2	2.1	3.0	2.1	3.0
36	1.9	1.5	2.7	3.8	2.7	3.8
40	2.5	2.0	3.5	5.0	3.5	5.0
44	3.0	2.4	4.2	6.0	4.2	6.0
48	3.8	3.0	5.3	7.6	5.3	7.6

Note: Slings having working loads below 1 tonne are usually marked in kilograms.
1 tonne = 1000 kilograms.

(Visual inspection should be carried out prior to and during use at all times.)

UNIFORM METHOD – GRADE 8

TABLE 5: WORKING LOAD LIMITS: GENERAL-PURPOSE GRADE 8 CHAIN SLINGS - UNIFORM LOAD
METHOD OPERATING IN ACCORDANCE WITH EN 818-4

(Note: For higher grades, refer to manufacturer's specifications.)

Chain Size (mm)	Single-leg	Two-leg		Three-leg	Four-leg	Choked Sling	Endless	Min Di of Pin
Angle	0°	β 0-45° α 0-90°	β 45-60° α 90-120°	β 0-45° α 0-90°	β 45-60° α 90-120°	0-90°	90-120°	mm
	t	t	t	t	t	t	t	
6	1.12	1.60	1.12	2.36	1.70	1.20	2.25	60
7	1.50	2.12	1.50	3.15	2.24	1.20	2.25	60
8	2.00	2.80	2.00	4.25	3.00	2.60	4.80	85
10	3.15	4.25	3.15	6.70	4.75	4.30	8.10	110
13	5.30	7.50	5.30	11.20	8.00	6.40	12.00	135
16	8.00	11.20	8.00	17.00	11.80	9.20	17.20	160
19	11.20	16.00	11.20	23.60	17.00			
20	12.50	17.00	12.50	26.80	19.00			
22	15.00	21.20	15.00	31.50	22.40			
23	16.00	23.60	16.00	35.50	25.00	13.50	26.30	195
26	21.20	30.00	21.20	45.00	31.50	17.30	32.40	220
32	31.50	45.00	31.50	67.00	47.50	25.80	48.00	270

N.B. If a multiple-leg choker is being used, reduce SWL by 20%.

(Visual inspection should be carried out prior to and during use at all times.)

TRIGONOMETRIC METHOD – GRADE 80

TABLE 6: SPECIAL-PURPOSE SLINGS – TRIGONOMETRIC METHOD OF RATING

(Note: For higher grades, refer to manufacturer's specifications.)

Chain Size (mm)	Endless	Single-leg	Two-leg				Three-leg				Four-leg				Min Dia of Pin
Angle			α at 30°	α at 60°	α at 90°	α at 120°	β at 15°	β at 30°	β at 45°	β at 60°	α at 30°	α at 60°	α at 90°	α at 120°	mm
7	2.5	1.5	2.8	2.5	2.1	1.5	4.3	3.8	3.1	2.2	5.8	5.2	4.2	3.0	60
8	3.1	2.0	3.9	3.5	2.8	2.0	5.8	4.2	4.2	3.0	7.7	6.9	5.7	4.0	
10	3.1	2.0	6.1	5.5	4.5	3.2	9.2	8.3	6.7	4.8	12.3	11.0	9.0	6.4	85
13	5.0	3.2	10.4	9.3	7.6	5.4	15.6	14.0	11.4	8.1	20.8	18.7	15.2	10.8	110
16	8.5	5.4	15.4	13.8	11.3	8.0	23.1	20.7	16.9	12.0	30.9	27.7	22.6	16.0	135
19	12.0	8.0	22.2	19.9	16.2	11.5	33.3	29.8	24.3	17.2	44.4	39.8	32.5	23.0	160
20			24.7	22.1	17.0	12.8	37.0	33.2	27.1	19.2	49.4	44.5	36.2	25.6	
22			29.9	26.8	21.5	15.5	44.9	40.2	32.8	23.2	59.8	53.7	43.8	31.0	
23			32.6	29.2	23.9	16.9	48.9	43.9	35.8	25.3	65.3	58.5	47.8	33.8	195
26	20.0	12.5	41.7	37.4	30.5	21.6	62.5	56.1	45.8	32.4	83.4	74.8	61.0	43.2	220
32	24.0	15.5	61.8	55.4	45.2	32.0	92.7	83.1	67.8	48.0	123.6	110.8	90.5	64.0	270

N.B. If a multiple-leg choker is being used, reduce SWL by 20%.

(Visual inspection should be carried out prior to and during use at all times.)

3.5 WIRE ROPE

- 3.5.1 Refer to BS 302 or equivalent and to Tables 7 and 8 on pages 27 and 28 for safe working loads (SWLs). For wire ropes not covered by this table, the SWL is 5:1, based on the manufacturer's certificate.
- 3.5.2 Refer to ISO 4309 or equivalent for discarding wire ropes.
- 3.5.3 Wire rope shall not be used around a diameter less than:
 - (a) Soft eye single-leg sling – 2 x rope diameter.
 - (b) Grommet or basket – 4 x rope diameter.

3.6 COMPONENTS

- 3.6.1 The factor of safety of any sling components used in lifting gear and not manufactured to a Standard, shall be rated in accordance with the equipment it is to be used with, e.g:

Webbing sling metal components 4:1;

Wire rope 5:1;

Chain 4:1.

A sample shall be either tested to destruction or the relevant engineering calculations provided by a competent person and a proof load test carried out in accordance with the above safety factors.

(Visual inspection should be carried out prior to and during use at all times.)

TABLE 7: SWLS FOR SLINGS CONSTRUCTED FROM WIRE ROPES WITH FIBRE CORES - (1770 TENSILE STRENGTH STEEL) 6 X 19 - 6 X 41 EXCLUDING 6 X 24

Rope Diameter	SWL									
	Single-leg slings			Multi-leg slings						
	Single, terminated by ferrules or splices	Single, terminated by grommet	Leg angle $0^\circ < \delta - 90^\circ$ $0^\circ < \beta - 45^\circ$				Leg angle $90^\circ < \delta - 120^\circ$ $45^\circ < \beta - 20^\circ$			
			Two-leg		Three- or Four-leg		Two-leg		Four-leg	
			Single	Grommet	Single	Grommet	Single	Grommet	Single	Grommet
A	B	C	D	E	F	G	H	I	J	K
mm	t	t	t	t	t	t	t	t	t	t
5	0.276*	0.414*	0.386*	0.579*	0.579*	0.869*	0.276*	0.414*	0.414*	0.621
6	0.398	0.597	0.557	0.836	0.836	1.2	0.398	0.597	0.597	0.895
7	0.542	0.813	0.759	1.1	1.1	1.7	0.542	0.813	0.813	1.2
8	0.762	1.1	1.0	1.5	1.6	2.3	0.762	1.1	1.1	1.6
9	0.962	1.4	1.3	1.9	2.0	2.9	0.962	1.4	1.4	2.1
10	1.2	1.8	1.7	2.5	2.5	3.8	1.2	1.8	1.8	2.7
11	1.4	2.1	1.9	2.9	2.9	4.4	1.4	2.1	2.1	3.1
12	1.7	2.5	2.4	3.5	3.5	5.2	1.7	2.5	2.5	3.7
13	2.0	3.0	2.8	4.2	4.2	6.3	2.0	3.0	3.0	4.5
14	2.3	3.5	3.2	4.9	4.8	7.3	2.3	3.5	3.4	5.2
16	3.0	4.5	4.2	6.3	6.3	9.4	3.0	4.5	4.5	6.7
18	3.8	5.7	5.3	8.0	8.0	11.9	3.8	5.7	5.7	8.5
19	4.3	6.4	6.0	8.9	9.0	13.4	4.3	6.4	6.4	9.6
20	4.7	7.1	6.6	9.9	9.8	14.9	4.7	7.1	7.0	10.6
22	5.7	8.6	8.0	12.0	11.9	18.0	5.7	8.6	8.5	12.9
24	6.8	10.2	9.5	14.3	14.3	21.4	6.8	10.2	10.2	15.3
26	8.0	12.0	11.0	16.8	16.8	25.2	8.0	12.0	12.0	18.0
28	9.3	14.0	13.0	19.6	19.5	29.4	9.3	14.0	13.9	21.0
32	12.1	18.2	16.9	25.5	25.4	38.2	12.1	18.2	18.1	27.3
35	14.5	21.8.1	20.3	30.5	30.4	45.8	14.5	21.8	21.7	32.7
36	15.4	23.1	21.5	32.3	32.3	48.5	15.4	23.1	23.1	34.6
38	17.1	25.7	23.9	35.9	35.9	53.9	17.1	25.7	25.6	38.5
40	19.0	28.5	26.6	39.9	39.9	59.8	19.0	28.5	28.5	42.7

* SWLs of less than 1.0 tonnes are normally cited in kilograms. Refer to BS 302 for further details.

(Visual inspection should be carried out prior to and during use at all times.)

**TABLE 8: SWLS FOR SLINGS CONSTRUCTED FROM WIRE ROPES WITH STEEL CORES (1770 TENSILE STRENGTH STEEL)
6 x 19 - 6 x 41 Excluding 6 x 24**

Rope diameter	SWL				
	Single-leg slings	Multi-leg slings			
	Single, terminated by ferrules or splices	Leg angle 0° < δ - 90° 0° < β - 45°		90° < δ - 120° 45° < β - 60°	
		Two-leg: single-part leg	Three- or four-leg: single-part leg	Two-leg: single-part leg	Four-leg: single-part leg
A	L	M	N	P	R
mm	t	t	t	t	t
8	0.822*	1.1	1.7	0.822*	1.2
9	1.0	1.4	2.1	1.0	1.5
10	1.3	1.8	2.7	1.3	1.9
11	1.5	2.1	3.1	1.5	2.2
12	1.8	2.5	3.8	1.8	2.7
13	2.1	2.9	4.4	2.1	3.1
14	2.5	3.5	5.2	2.5	3.7
16	3.3	4.6	6.9	3.3	4.9
18	4.1	5.7	8.6	4.1	6.1
19	4.6	6.4	9.6	4.6	6.9
20	5.1	7.1	10.7	5.1	7.6
22	6.2	8.7	13.0	6.2	9.3
24	7.4	10.3	15.5	7.4	11.1
26	8.6	12.0	18.0	8.6	12.9
28	10.0	14.0	21.0	10.0	15.0
32	13.1	18.3	27.5	13.1	19.6
35	15.7	22.0	33.0	15.7	23.5
36	16.6	23.2	34.8	16.6	24.9
38	18.5	25.9	38.8	18.5	27.7
40	20.6	28.8	43.2	20.6	30.9

* SWLs of less than 1 tonne are normally cited in kilograms. Refer to BS 302 for further details.

(Visual inspection should be carried out prior to and during use at all times.)

PART 4: ROPE SPLICES

4.1 FIBRE ROPES

- 4.1.1 Most common splices, whether in natural fibre or synthetic fibre, are:
- (a) Eye splice, soft eye;
 - (b) Eye splice with thimble;
 - (c) Long splice;
 - (d) Short splice; or
 - (e) Rope protrusion of 1 x rope diameter or in accordance with the manufacturer's specifications or to accepted industry standards.
- 4.1.2 Eye splices in natural fibre ropes must have a minimum of four (4) full tucks against the lay of the rope or as per industry requirements.
- 4.1.3 Eye splices in synthetic fibre ropes must have five (5) full tucks against the lay of the rope or as per industry requirements.

4.2 WIRE ROPE

- 4.2.1 There are various ways of forming eye splices on wire rope for lifting purposes. The following are examples:
- (a) Manual soft eye — to accepted industry standards;
 - (b) Manual hard eye (with thimble) — to accepted industry standards;
 - (c) Mechanical soft eye (Talurit) — in accordance with manufacturer's specifications; or
 - (d) Mechanical hard eye (thimble and Talurit) — in accordance with manufacturer's specifications.

Note: The rope must protrude past the end of the Talurit unless to a specific design.

- 4.2.2 Wire ropes should be inspected for:
- (a) Broken wires;
 - (b) Kinks and deformation;
 - (c) Corrosion;

(Visual inspection should be carried out prior to and during use at all times.)

(d) Damage to terminations; and

(e) Excessive wear.

For more details, refer to ISO 4309.

4.3 WIRE ROPE THIMBLES

4.3.1 The nominal size of a thimble is that of the rope with which it is to be used. Refer to the relevant Standard, BS 464, or equivalent.

4.4 WIRE ROPE (BULLDOG) GRIPS

4.4.1 Do not use wire rope (bulldog) grips on any load-hoisting rope. They are only suitable for forming an eye on stays or guys.

4.4.2 Wire rope (bulldog) grips must comply with DIN 1142 or equivalent Standard as per the drawing.

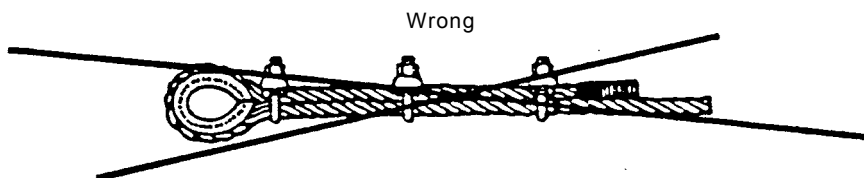
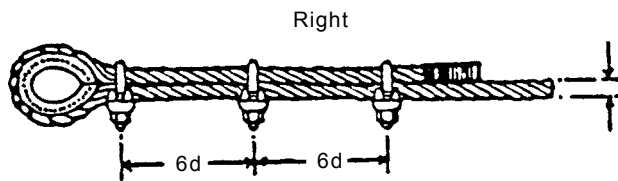
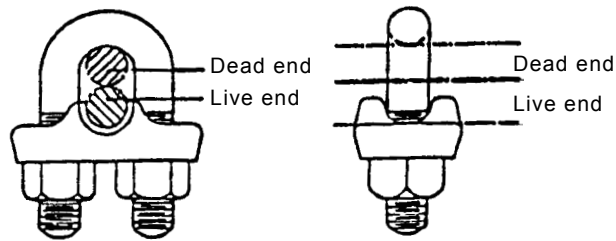

(Visual inspection should be carried out prior to and during use at all times.)

TABLE 9: WIRE ROPE GRIPS DIN 1142

Size Nominal Diameter mm	Required Number of Wire Rope Grips to Attain 85% of Rope Minimum Breaking Load	Required Tightening Torque to Obtain Required Efficiency Newton metres
5.0	3.0	2.0
6.5	3.0	3.5
8.0	4.0	6.0
10.0	4.0	9.0
13.0	4.0	33.0
16.0	4.0	49.0
19.0	4.0	68.0
22.0	5.0	107.0
26.0	5.0	147.0
30.0	6.0	212.0
34.0	6.0	296.0
40.0	6.0	363.0

TABLE 10: WIRE ROPE GRIPS - FEDERAL SPEC. FFC-450

- >> Drop Forged
- >> Material: High tensile steel
- >> Finish: Hot dip galvanised

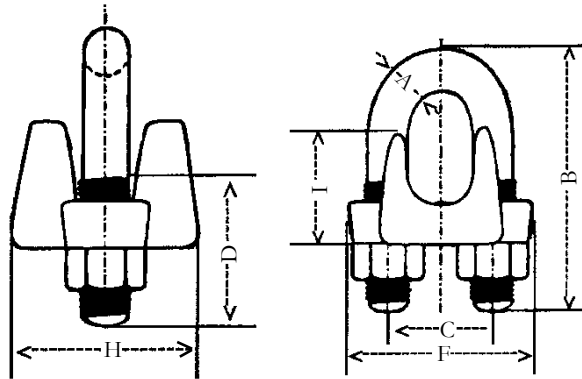

Rope Dia (in)	Bow Dia A (mm)	Bow Length B (mm)	Bolt Centres C (mm)	Thread Length D (mm)	Base Length F (mm)	Base Thickness H (mm)	Base Height I (mm)
5/16	10	45	22	19	43	33	18
3/8	11	49	26	19	49	42	25
7/16	12	60	30	25	58	46	26
1/2	13	61	30	26	58	48	27
5/8	14	74	33	32	64	52	33
3/4	16	86	38	37	72	57	37
7/8	19	98	45	40	80	62	40
1-0	19	108	48	46	88	67	44
1-1/8	19	117	51	51	91	72	48
1-1/4	22	130	59	54	105	79	56
1-3/8	22	140	60	59	108	79	58
1-1/2	22	147	66	60	112	86	64
1-5/8	26	161	70	67	121	92	67
1-3/4	29	175	78	74	134	97	78
2-0	32	195	86	78	152	113	87

(Visual inspection should be carried out prior to and during use at all times.)

TABLE 11: REQUIRED TIGHTENING TORQUE AND MINIMUM NUMBER OF FF-C-450 GRIPS TO ATTAIN 80% OF ROPE MINIMUM BREAKING LOAD.

Wire Rope Dia (In)	Minimum Number of Grips	Torque Value (Ft. Lbs)	Wire Rope Dia (In)	Minimum Number of Grips	Torque Value (Ft. Lbs)
$\frac{5}{16}$	2	30	$1-\frac{1}{8}$	6	225
$\frac{3}{8}$	2	45	$1-\frac{1}{4}$	7	360
$\frac{1}{2}$	3	65	$1-\frac{3}{8}$	7	360
$\frac{5}{8}$	3	95	$1-\frac{1}{2}$	8	360
$\frac{3}{4}$	4	130	$1-\frac{5}{8}$	8	430
$\frac{7}{8}$	4	225	$1-\frac{3}{4}$	8	590
1-0	5	225	2-0	8	750

Note: Imperial Measurements

(Visual inspection should be carried out prior to and during use at all times.)

PART 5: FITTINGS, SHEAVES AND BLOCKS

5.1 WEDGE-TYPE ROPE SOCKETS

- 5.1.1 The wedge socket must be properly set up as per the relevant Standard BS 7166, or equivalent. Protruding rope shall be a length of 6 x diameter of the rope.
- 5.1.2 Wedge-type rope sockets should be inspected for damage to the rope, wedge and socket.
The wedge should be removed with a punch.
- 5.1.3 Correct methods of fitting rope to wedge and use of rope grips.

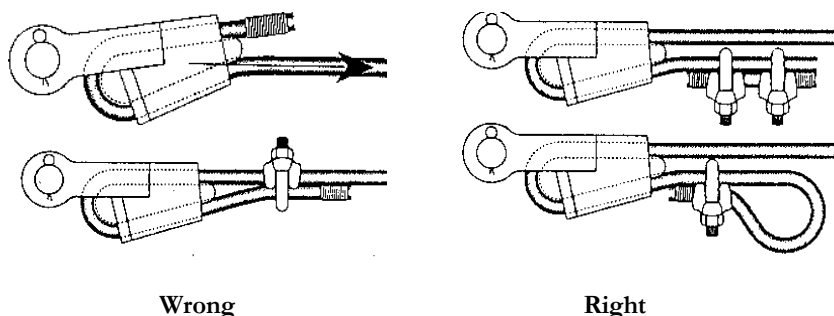

5.2 RINGS

- 5.2.1 Rings for attaching single- and multi-leg slings onto lifting hooks must be of sufficient size and strength to ensure that the safe working capacity of the sling is in no way impaired. Any attaching of slings to rings must ensure that both can move freely on each other, and that no undue wear or distortion results in either component (BS 3458:1985) or equivalent.

5.3 SHACKLES

- 5.3.1 Shackles may be made of high-tensile steel or alloy steel. Refer to the relevant Standard BS 3032 or Federal Specification RR 271 or equivalent. Load chart on page 34.

(Visual inspection should be carried out prior to and during use at all times.)

5.3.2 Shackles to be used for hoisting purposes must be marked with the SWL.

5.3.3 Shackles should be inspected for:

- (a) Mechanical damage to pin or body;
- (b) Correct tensile pin fitted;
- (c) Correct pin length; and
- (d) Wear.

ALLOY HI-LOAD STANDARD SHACKLES

Material: Body and pin high tensile steel, quenched and tempered.

Safety factor: 6 times SWL = minimum breaking strength.

Finish: Galvanised.

Standard: US Federal Specification RR-C-271 or equivalent.

TABLE 12: STANDARD SHACKLES

Safe Working Load	Dia Bow	Dia Pin	Inside Width	Inside Length		Width of Bow	Approximate Weight Each	
				Dee Type	Bow Type		Screw Pin	Safety Pin
	D	d	a	C	C	2r	kgs	
Metric tonnes	mm	mm	mm	mm	mm	mm	Screw Pin	Safety Pin
0.33	5	6	10.0		22	16	0.02	
0.50	6	8	12.0		29	20	0.06	0.07
0.75	8	10	13.5	27	32	21	0.11	0.13
1.00	10	11	16.0	31	36	26	0.15	0.17
1.50	11	13	18.0	37	43	29	0.21	0.25
2.00	13	16	22.0	43	51	32	0.37	0.44
3.25	16	19	27.0	51	64	43	0.65	0.79
4.75	19	22	31.0	59	76	51	1.06	1.26
6.50	22	25	36.0	73	83	58	1.56	1.88
8.50	25	28	43.0	85	95	68	2.32	2.78
9.50	28	32	47.0	90	108	75	3.28	3.87
12.00	32	35	51.0	94	115	83	4.51	5.26
13.50	35	38	57.0	115	133	92	5.93	6.94
17.00	38	42	60.0	127	146	99	7.89	8.79
25.00	45	50	74.0	149	178	126	13.40	14.99
35.00	50	57	83.0	171	197	146	18.85	20.65
42.50	57	65	95.0	190	222	160	26.06	29.01
55.00	65	70	105.0	203	254	185	37.86	41.05
85.00	75	80	127.0	230	330	190	58.68	62.24
120.00	89	95	146.0	267	381	238		110.00



Bow shackle with screw pin



Dee shackle with screw pin



Bow safety anchor shackle



Dee safety anchor shackle

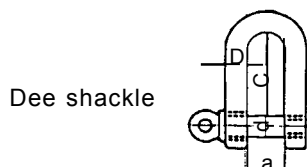

Dee shackle

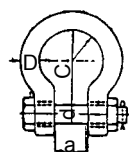

Bow shackle

(Visual inspection should be carried out prior to and during use at all times.)

TABLE 13: LARGE DEE SHACKLES BS 3032 TABLE 2

SWL Tonnes	mm d	mm D	mm a	mm C	Weight Each kg
0.25	6	10	13	25	0.11
0.50	10	13	19	38	0.17
0.75	13	16	29	54	0.35
1.50	16	19	32	64	0.66
2.00	19	22	38	73	1.02
3.00	22	25	44	83	1.57
3.75	25	28	51	95	2.30
5.00	28	32	54	105	3.20
6.00	32	35	60	114	4.30
7.00	35	38	67	127	5.40
9.50	38	45	70	137	6.80
11.25	42	48	76	146	8.70
13.00	45	51	83	156	11.00
14.25	48	54	92	178	14.30
16.25	51	57	98	187	20.00
18.00	54	60	105	197	26.38
20.00	57	64	108	210	28.27
25.00	64	73	121	235	35.00
30.00	70	79	133	260	49.03
35.00	76	86	146	279	63.56
40.00	79	89	149	292	71.73
50.00	89	102	171	330	101.24
65.00	102	114	191	375	150.73
80.00	114	127	219	419	214.74

Finish: Self-colour or galvanised.

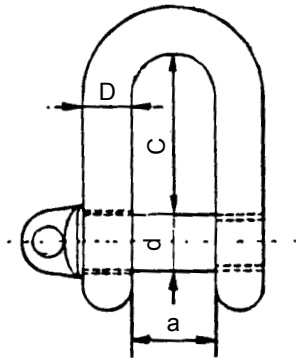

(Visual inspection should be carried out prior to and during use at all times.)

5.4 RIGGING SCREWS AND TURNBUCKLES

- 5.4.1 Rigging screws and turnbuckles should conform to BS 4429 or equivalent.
- 5.4.2 Rigging screws and turnbuckles should be inspected for:
- (a) Thread damage and thread engaged to full length of threaded body;
 - (b) Deformation; and
 - (c) Corrosion.

TYPES OF TURNBUCKLE

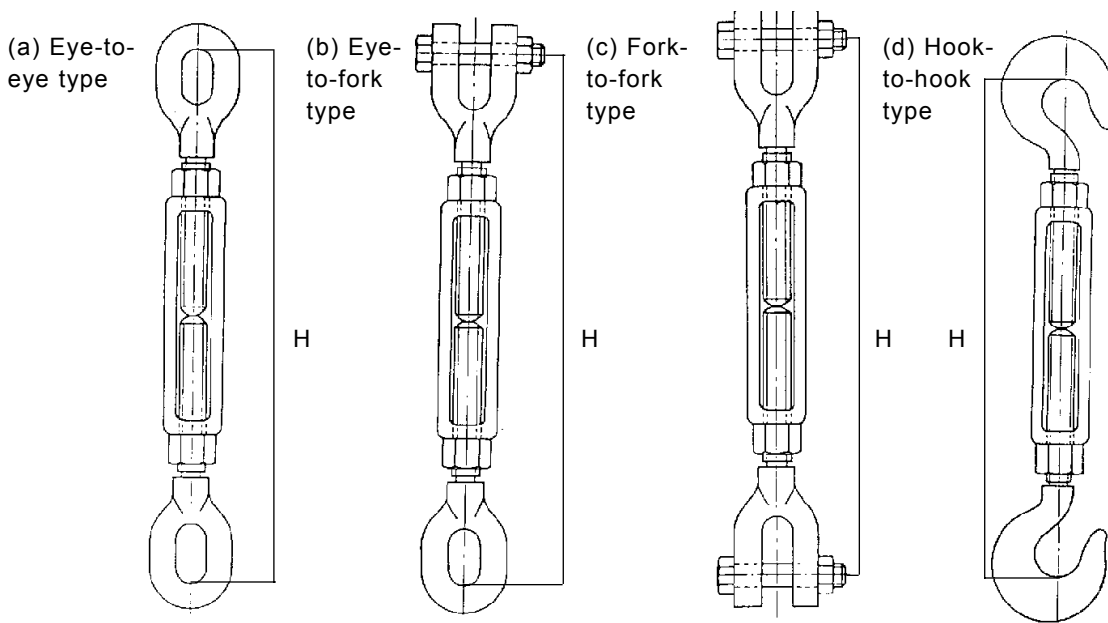

TYPES OF RIGGING SCREW

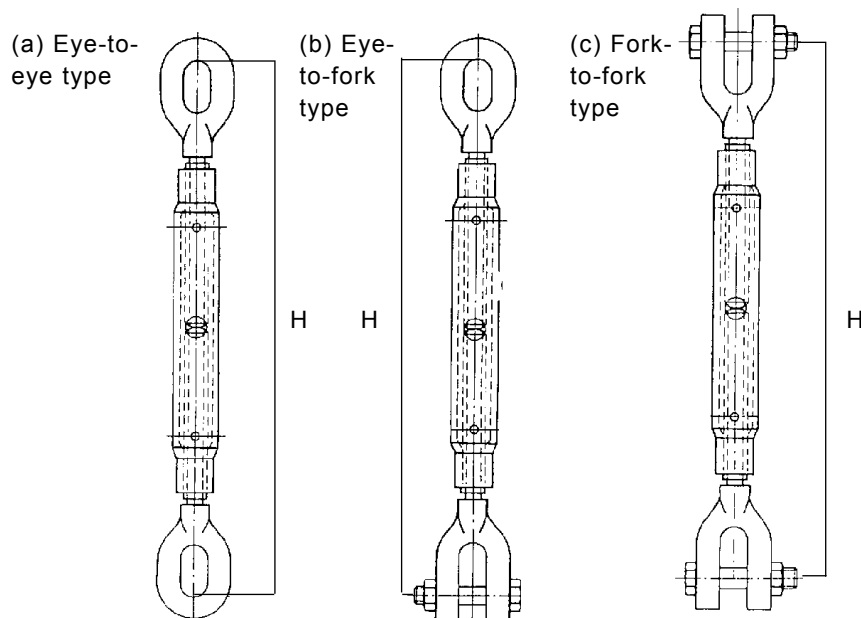

(Visual inspection should be carried out prior to and during use at all times.)

TABLE 14: SAFE WORKING LOADS FOR RIGGING SCREWS AND TURNBUCKLES TO BS 4429

Thread Diameter (A)	Safe Working Load (SWL)	Thread Diameter (A)	Safe Working Load (SWL)
mm	tonnes	mm	tonnes
8	0.2	39	6.0
10	0.3	42	7.5
12	0.5	48	10.0
16	0.75	56	15.0
20	1.25	64	20.0
22	2.0	72	25.0
27	3.0	76	30.0
30	4.0	85	40.0
33	5.0	100	50.0

5.5 SNATCH, SHEAVE AND CARGO BLOCKS

5.5.1 Blocks should be to the relevant Standard:

- BS 4018: Specification for pulley blocks for use with wire rope for a maximum lift of 25 tonnes in combination.
- BS 4536: Specification for heavy-duty pulley blocks for use with wire rope.
- BS MA 47: *Code of practice for ships' cargo blocks*, or its equivalent, and tested in accordance with the relevant Standard.

5.5.2 The safe working load must be permanently marked on all blocks and the unique identifying number.

5.5.3 Sheaves and cargo blocks should be inspected:

- For corrosion;
- For deformation;
- For sheave and pin wear;
- To ensure the sheave freely turns; and
- To ensure that snatch block retaining pins correctly retain the gate assembly.



(Visual inspection should be carried out prior to and during use at all times.)

Example: How SWL rating of single sheave block is calculated.

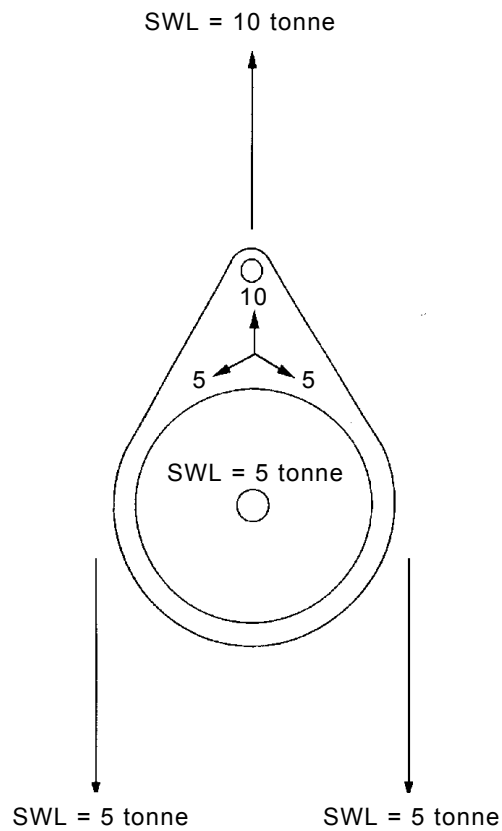

5.6 LIFTING BEAMS, SPREADERS AND FRAMES

5.6.1 To be designed, manufactured and tested as per AS 1418, BS 2573, or equivalent.

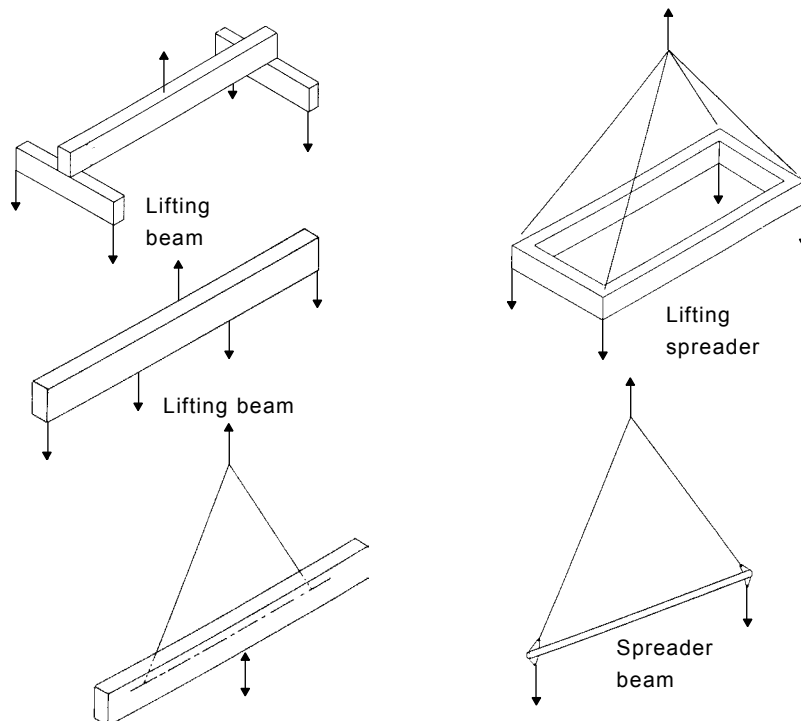

(Visual inspection should be carried out prior to and during use at all times.)

5.7 EYEBOLTS FOR LIFTING

- 5.7.1 Refer to relevant Standard BS 4278 or equivalent.
- 5.7.2 Eyebolts with the pull horizontal to the plate, should be shoulder-type only and be used in pairs. The load taken by a single eyebolt should be no more than 25% of its marked SWL.
- 5.7.3 Eyebolts must be tightened so that the shoulder is flush with the item being lifted.

TABLE 15: MAXIMUM RECOMMENDED WORKING LOADS FOR COLLAR EYEBOLTS (METRIC THREADS) WHEN USED IN PAIRS FOR INCLINED LOADING CONDITIONS

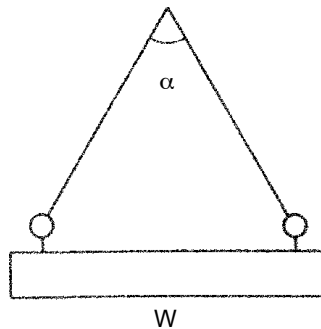

Thread Size Metric	Axial SWL of Single Eye Bolt	Maximum Load W To Be Lifted by a Pair of Eyebolts When the Angle Between Slings is:		
		$0^\circ < \alpha < 30^\circ$	$30^\circ < \alpha < 60^\circ$	$60^\circ < \alpha < 90^\circ$
mm	tonnes	tonnes	tonnes	tonnes
12	0.40	0.50	0.32	0.20
16	0.80	1.00	0.64	0.40
20	1.60	2.00	1.25	0.80
24	2.50	3.20	2.00	1.25
30	4.00	5.00	3.20	2.00
36	6.30	8.00	5.00	3.20
42	8.00	10.00	6.30	4.00
48	10.00	12.50	8.00	5.00
52	12.50	16.00	10.00	6.30
56	16.00	20.00	12.50	8.00
64	20.00	25.00	16.00	10.00
72	25.00	32.00	20.00	12.50
Reduction Factor		0.63	0.40	0.25

Some eye bolts, whilst complying with British Standards, may be marked with lower safe working loads than those shown. In these cases, the reduced safe working load for angular loading when used in pairs may be obtained by using the reduction factor given at the foot of the tables for each type of eye bolt.

5.8 CHAINBLOCKS

- 5.8.1 Refer to BS 3243 or equivalent. Chainblocks must be supplied with relevant test certificates and used in accordance with manufacturer's recommendations.
- 5.8.2 All components must have a regular inspection.

(Visual inspection should be carried out prior to and during use at all times.)

5.9 LEVER HOISTS

- 5.9.1 Refer to BS 4898 or equivalent and to be supplied with relevant test certificates and used in accordance with manufacturer's recommendations.
- 5.9.2 All components must have a regular inspection.

5.10 HOOKS

- 5.10.1 Refer to BS 2903 or equivalent.
- 5.10.2 Safety catches are not mandatory on hooks used as a component of lifting slings or as per accepted industry standards.

5.11 OTHER GENERAL GEAR

- 5.11.1 'Tirfor'-type winches must be used in accordance with the manufacturer's specifications using the correct rope size and construction.
- 5.11.2 Lifting components cast in concrete are to have a minimum safety factor of 3:1.
- 5.11.3 Lifting clutches/eyes for use in lifting items in 5.11.2 are to have a minimum safety factor of 5:1.
- 5.11.4 Any other lifting equipment must be in accordance with manufacturer's recommendations otherwise in accordance with paragraph 3.5.1.

5.12 INSPECTION

- 5.12.1 It is recommended that all lifting tackle be examined by a competent person on a regular basis. This should not exceed a 12-month period, depending on frequency, type of use, and environmental conditions.
- 5.12.2 Visual inspection prior to and after use is a requirement.
- 5.12.3 Any proof loading shall be carried out by a competent person in accordance with the relevant Standard or the manufacturer's recommendations.

5.13 REGISTER

- 5.13.1 A register shall be kept of all lifting tackle as per industry requirements but is not mandatory for flat web, round slings, wire rope slings, or shackles. An example of this register is given on the following page.

(Visual inspection should be carried out prior to and during use at all times.)

This register should show date of last recorded examination or test and any alterations.

(Visual inspection should be carried out prior to and during use at all times.)

EXAMPLE: THOROUGH EXAMINATION OF ALL CHAINS, ROPES OR LIFTING TACKLE

Size	Distinguishing number or mark and description sufficient to identify the chain, rope or lifting tackle	Number of certificate of test and examination	Date when chain, rope or tackle was first taken into use	Particulars of each thorough examination of all chains, ropes or lifting tackle			
				Date and by whom carried out			Particulars of any defect found which may affect the safe working load, and steps taken to remedy such a defect. (To be initialled and dated.)
				Date and name	Date and name	Date and name	

(Visual inspection should be carried out prior to and during use at all times.)

PART 6: RIGGING FOR CRANE WORK AND BUILDING CONSTRUCTION

6.1 EVALUATING THE LOAD

- 6.1.1 The operator should take all practicable steps to establish the weight of any load. An intelligent guess is not good enough. A drawing may be available giving the weight or it may be calculable within reasonable limits of accuracy. In the case of multi-piece loads (e.g. a bundle of steel rods), one item may be weighed to calculate the total weight of the load. If it is likely that the load may have to be lifted again, the weight should be clearly marked on it.

6.2 LOAD ESTIMATION — WEIGHT AND CENTRE OF GRAVITY

- 6.2.1 The importance of knowing, with reasonable accuracy, the weight of a load to be lifted and the position of its centre of gravity, is stressed throughout this code. The following gives guidance as to the various ways of obtaining this information.

WEIGHT

1. Look to see if the weight is marked on the load. If it is, check to ensure that it is the weight of all parts of the load; (a machine tool, for example, may not include the driver motor).
2. Check the weight stated on any documentation.
3. Look at the drawing of the load. If the weight is marked, check as in (1) above to ensure it includes all parts of the load.
4. If the load is still on a trailer or truck, weigh it.
5. Estimate the weight of the load by using tables of weights. In this respect, BS 4 gives the weight of rolled steel sections. The following table gives approximate weights for other materials. Check with the supplier for accurate figures.

(Visual inspection should be carried out prior to and during use at all times.)

TABLE ??: EXAMPLE OF MATERIAL WEIGHTS

Material	Weight in kg per cubic m
Aluminium	2700
Brass	8500
Brick	2100
Coal	1450
Copper	8800
Concrete	2400
Iron-steel	7700
Lead	11200
Oil	800
Paper	1120
Water	1000
Wood	800

Notes

1. In some cases, these figures are average only and the actual weight may vary according to the particular composition/water content, etc.
2. All figures have been rounded for convenience of use.
3. When dealing with hollow body, check whether it contains anything and whether any such contents are liable to move.

IMPERIAL/METRIC CONVERSION

1 ton = 1016 kg = 2240 lb

1 tonne = 1000 kg = 2204.6 lb

US ton = 909 kg = 2000 lb

CENTRES OF GRAVITY

The “centre of gravity” (CoG) is a point which, if the load could be suspended from it, the load would be in perfect balance.

The crane hook needs to be directly over the centre of gravity, for the load to be stable.

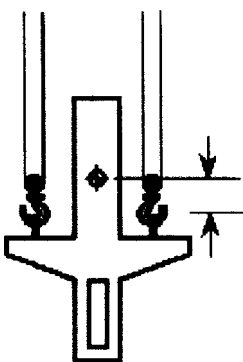

This load **is not** stable. The hook is over the centre of gravity, but the centre of gravity is above the crane hook. This load is top-heavy, and could overturn while being craned.

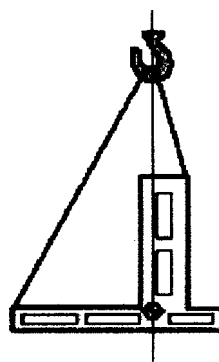

This load **is** stable. The hook is right over the load's centre of gravity.

(Visual inspection should be carried out prior to and during use at all times.)

Lifting a load with the centre of gravity offset will cause the load to shift until a balance is restored.

Start like this ...

And end up like this ...

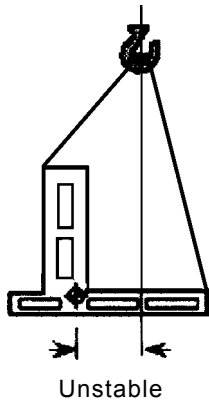

The hook **is not** over the centre of gravity.

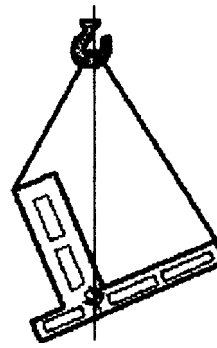

The load will shift until the centre of gravity is under the hook.
This will make landing the load very difficult, and could cause major problems in crainage.

6.3 VOLUMES OF COMMON SHAPES

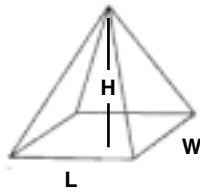

$$\text{Pyramid} = \frac{1}{4} \times L \times W \times H$$

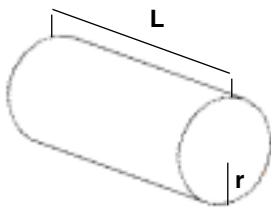

$$\text{Solid cylinder} = \pi r^2 \times L$$

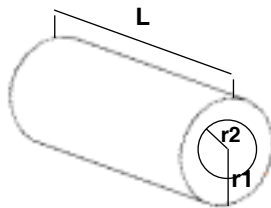

$$\text{Thick walled pipe} = \pi(r1^2 - r2^2) \times L$$

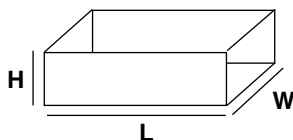

$$\text{Rectangular solid} L \times W \times H$$

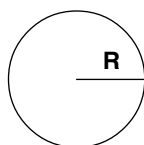

$$\text{Sphere} = 4\pi \times R^3$$

(Visual inspection should be carried out prior to and during use at all times.)

6.4 LOAD SECURITY — BALANCE AND STABILITY

Before lifting it is essential to ensure that, when clear of the ground, the load will adopt the intended attitude and remain securely attached to the lifting appliance without overloading any of the lifting gear. This means that the load must be both balanced and stable.

BALANCE

In the majority of lifts it will be intended that the load will remain level when clear of the ground. To achieve this it is first necessary to position the hook of the lifting appliance vertically above the centre of gravity of the load.

The legs of the sling(s) should be distributed as evenly as is practicable according to the lifting points available. The angle which the individual leg makes with the vertical, affects the proportion of the load which will be imposed upon it and all legs should therefore be, so far as is practicable, at a similar angle to provide equal loading. If the load tilts on lifting, the load in the sling legs will become unequal. This effect is especially significant at small included angles between sling legs.

With rigid loads when three or more legs are employed, consideration should be given to how many of the legs will bear the weight as it may be found that only two or three will take the majority with the remaining legs providing a relatively small 'balancing force' only. If this is the case, larger capacity tackle will be required.

STABILITY

In this context, stability means 'resistance to toppling'. An object with a narrow base and a high centre of gravity will need less force to topple it than one with a wide base and a low centre of gravity.

As the height of the centre of gravity increases relative to the width of the base, a point will be reached where the object will fall over unless it is supported by external means. At this point the object is regarded as being unstable and the greater the support required the more unstable it is.

A similar situation exists with a suspended load. Forces which try to topple the load will inevitably be present (e.g. wind, acceleration, braking). It is essential, therefore, when slinging a load, to ensure that it is sufficiently stable to resist these toppling forces.

A load will be inherently stable if the lifting tackle is attached ABOVE the centre of gravity and properly positioned around it.

(Visual inspection should be carried out prior to and during use at all times.)

6.5 STRUCTURES

In this context, 'structure' refers to any support or anchorage for lifting equipment.

Frequently, such structures are primarily designed for other purposes, e.g. a building from which a runway is suspended. It is important to ensure that they are adequate for the purposes of lifting but, owing to the other loads which may be imposed, proof load testing alone is not adequate. The following procedure is therefore recommended.

OVERHEAD BEAMS AND GANTRIES

The overhead beams and gantries should be designed, tested and certified in accordance with the PECPR and *Approved Code of Practice for Cranes*.

Where it is intended to 'turn over' the load when in the air or to position it at an inclined attitude, special consideration should be given to the questions of balance and stability to ensure that at all stages of the operation the load remains balanced, stable and securely attached without overloading any item of lifting equipment.

On occasions, particularly when using a single leg sling, it may be necessary to lift a load such as a pipe or drum with the sling positioned a short distance away from the centre of gravity. The load, when lifted, will then take up a tilted position but will be inherently stable.

6.6 PACKING

The need for adequate packing between sling and load is emphasised throughout this code.

The objects of packing are:

1. To provide an adequate radius around which a sling may pass without unacceptable loss of load carrying capacity.
2. To assist the sling in gripping the load.
3. To prevent damage to the load itself.

With regard to 1. above it is important to realise that when a sling is bent around a corner its strength will be considerably reduced.

Whilst a small radius will prevent the cutting action of a sharp edge
IT WILL NOT PREVENT THE LOSS OF STRENGTH DUE
TO INCORRECT LOADING OF THE SLING.

For example, a chain sling passing around a corner may have one or more links loaded in bending, which could result in premature failure of the chain (see figure 2 overpage).

(Visual inspection should be carried out prior to and during use at all times.)

Minimum recommended corner radius for lifting

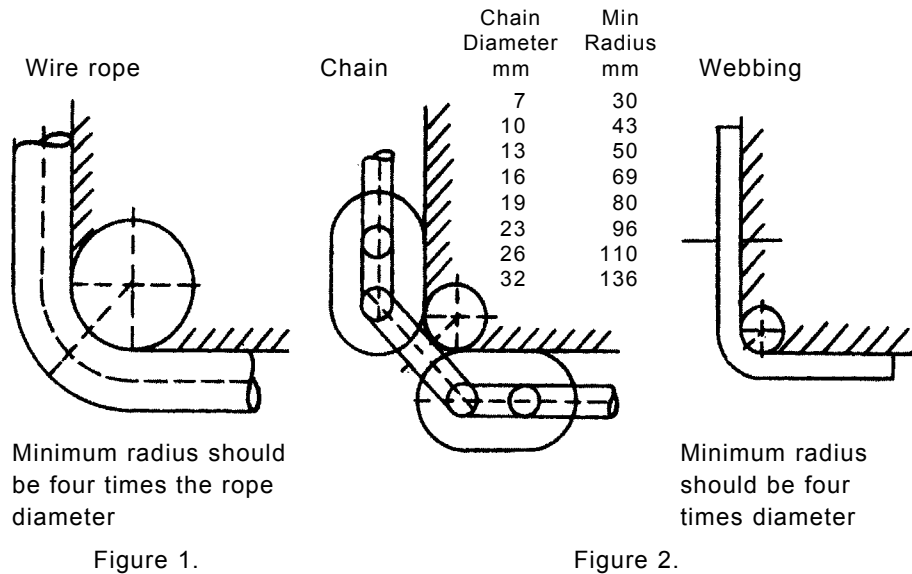

In the case of a wire rope sling, too small a radius would result in a permanent kink (see figure 1) and some of the individual wires being overloaded. Although in both of these examples failure may not occur immediately, permanent damage will have been done which may subsequently result in failure.

Various materials are suitable for packing. Whatever is used must be capable of taking the crushing forces which will be imposed upon it, and it should be positioned to make best use of its strength.

Where a particular load is lifted regularly, purpose designed reusable packing may be found economical, but for general purposes the operative should have available a good selection of materials according to the nature of the work (e.g. timber blocks, rubber, sections of old vehicle tyres, conveyor belts, etc.).

When positioning packing it is essential to ensure that it will stay in place throughout the lift, as packing which falls or flies out will be a hazard in itself as well as imposing shock loads upon the lifting equipment. It may, therefore, be necessary to provide some independent means of securing the packing in place.

The amount of packing required varies according to the particular job and in a code of this type it is not possible to cater for every situation. The illustrations in figure 3 provide some examples of good practice.

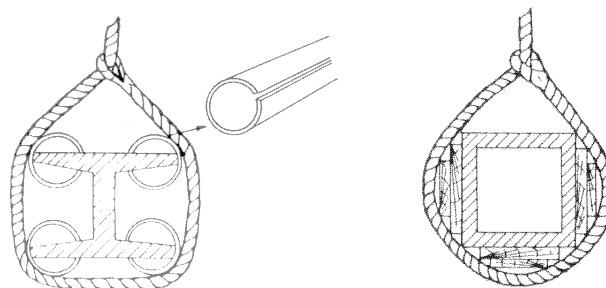

Figure 3 Good standard – adequate radius – no kinking.

(Visual inspection should be carried out prior to and during use at all times.)

6.7 SLINGS

MARKING

The following information should be permanently and legibly marked with:

1. Identification mark;
2. Safe working load at given angles; and
3. Any other information called for by the standard being worked to.

When a multi-leg sling is used with the sling legs at an angle, the load in the individual sling legs will increase as the angle between the legs becomes greater. This is illustrated in Figure A for two-leg slings.

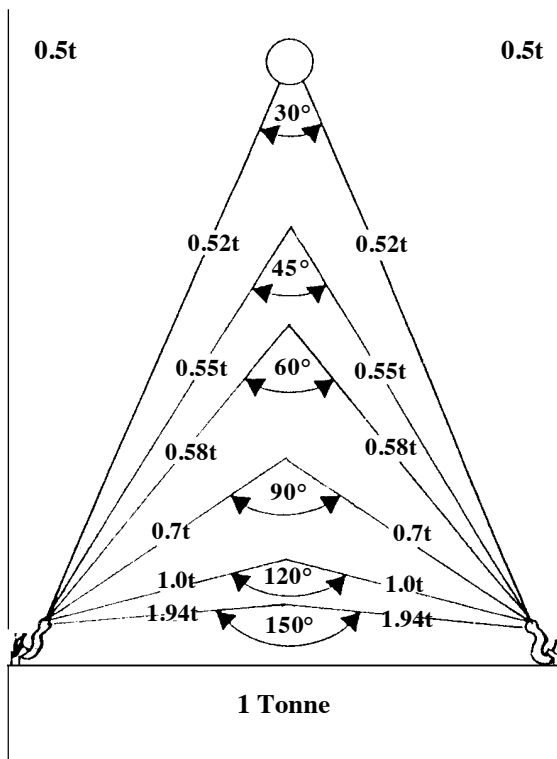

Figure A

Calculations for Two-Leg Sling

Using the angle load factors to determine the load on each leg:

$$W \times F = L$$

W = the weight of the load in tonnes.

F = Included angle factor on each leg.

L = The load on each leg.

Example:

For a 12-tonne load and sling angle of 60°.

The load on each leg is $12 \times 0.58 = 6.96$ tonnes per leg.

Angles greater than 120° are not accepted. The area below the dashed line shows excessive load in sling legs at extreme angles.

Thus, if a sling is to be used safely, allowance must be made for this included angle and this

is achieved by rating the sling in one of two ways. This matter is discussed in some detail in BS 6166 which specifies the method and factors to be used in calculating the safe working load.

The trigonometrical method is one which has been traditionally used and it allows the safe working load or decrease according to the angle between the sling legs.

The uniform load method simplifies matters by removing the need for tables and reducing the need for the operative to estimate angles.

Both of these methods do, however, assume certain conditions of use which are imposed to ensure that no part of the sling can

(Visual inspection should be carried out prior to and during use at all times.)

become overloaded. It is important to understand that although the weight to be lifted may be within the maximum lifting capacity of the sling, lifting in the wrong way can place an excess of load onto one part of the sling.



The following pages show chain slings but the principles apply to wire ropes, webbing slings and other slings.

(Visual inspection should be carried out prior to and during use at all times.)

RECOMMENDED METHODS OF SLINGING UNDER NORMAL CONDITIONS

(Where possible, hook from the inside.)

Single-Leg Slings

1. Straight Lift	2. Choke Hitch
 <p>SWL: The SWL will be a single-leg.</p> <p>Comments: A suitable method of lifting an effectively balanced load from a single lifting point.</p>	 <p>SWL: The SWL must be reduced by 20% in this application.</p> <p>Comments: This method forms a loop which tightens as the load is lifted. DO NOT attempt to force the bight into closer contact with the load. Allow the chain to assume its natural angle. Single-leg slings in choke hitch are not suitable for lifting long loads which might tilt or for any load which is not effectively balanced in the single loop.</p>

Caution: 1. Refer to minimum radius.
2. Refer to included angle chart.

(Visual inspection should be carried out prior to and during use at all times.)

Single-Leg Slings in Basket Hitch

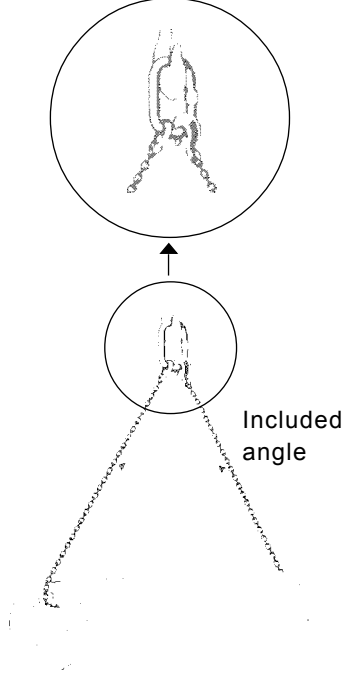
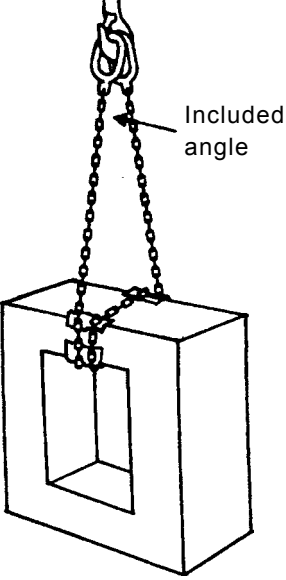
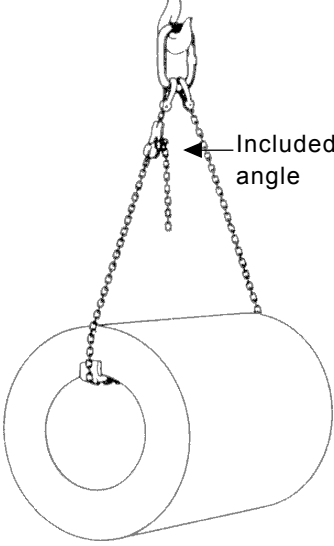
3. Single Leg in Basket Hitch (back hooked into top link)	4. Reeveable Collar Sling in Basket Hitch	5. Single Adjustable Basket Sling
		
<p>SWL: The SWL will be rated by that of a single-leg sling reduced by the included angle. Refer to relevant charts.</p>	<p>SWL: The SWL will be that for a two-leg sling reduced by the included angle. Refer to relevant charts.</p>	<p>SWL: The SWL will be that for a two-leg sling reduced by the included angle.</p>
<p>Comments: A single-leg sling back hooked to form a basket hitch assumes the appearance of a two-leg sling but it should never be rated as such. It should be noted that the master link is only designed for single leg loading and therefore the single leg WLL should never be exceeded.</p>		<p>Comments: A suitable master link must be fitted for two-leg rating.</p>

- Caution:** 1. Refer to minimum radius.
 2. Refer to included angle chart.

(Visual inspection should be carried out prior to and during use at all times.)

Two Single-Leg Slings Used Together

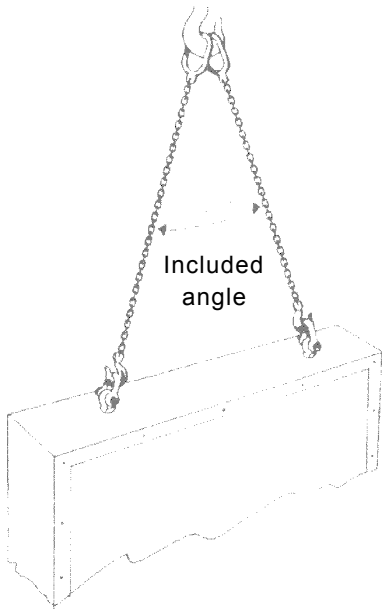
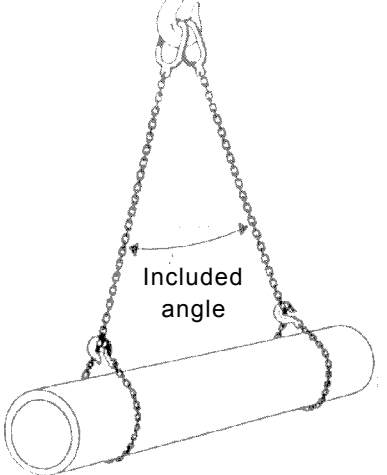
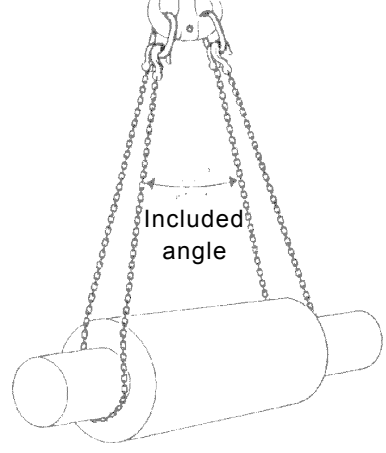
6. Two Single Legs in Straight Lift	7. Two Single Legs in Choke Hitch	8. Two Single Legs in Basket Hitch
	 <p data-bbox="644 786 1032 972">* SWL calculated as per No. 6 then reduced by 20% because it is choked. For loose items, double wrap is recommended.</p>	
<p>SWL: Rate as a two-leg sling. The SWL will therefore depend upon the included angle.</p>	<p>SWL: The SWL will be reduced by 20% in this application. Choke hitch with included angle greater than 60° is not recommended as sideways shifting may occur.</p>	<p>SWL: Rate as a two-leg sling. The SWL should be no more than that applicable to an equivalent two-leg sling.</p>
<p>Comments: Two single-leg slings should not be used together to form a pair unless:</p> <ol style="list-style-type: none"> 1. They are of the same type, grade, size and length. 2. They are both marked with the same SWL. 3. The crane hook is large enough to comfortably accept both upper terminal fittings of the slings. 		

- Caution:**
1. Refer to minimum radius.
 2. Refer to included angle chart.

(Visual inspection should be carried out prior to and during use at all times.)

Double-Leg Slings

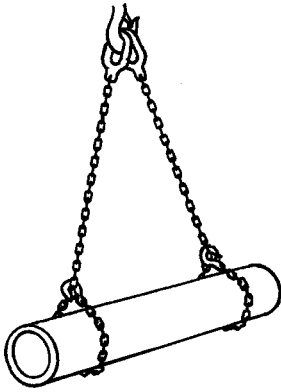
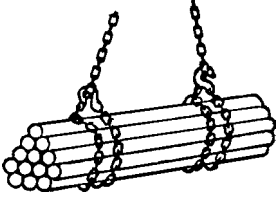
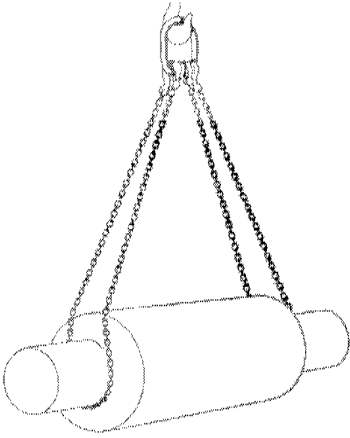
1. Straight Lift	2. Choke Hitch	3. Basket Hitch
	  <p data-bbox="571 929 925 1041">N.B. For loose items or a better grip, double wrap is recommended.</p>	
<p>SWL: Rate as per load chart tables depending on included angle.</p>	<p>SWL: The SWL is calculated as per No. 1 then reduced by 20%.</p>	<p>SWL: Rate as per load chart table depending on included angle. Be aware of minimum pin diameter for basket hitch.</p>
<p>In example 3 – Basket Hitch – the sling assumes the appearance of a four-leg sling but it should be noted that the master link will be designed for two-leg loads only and the sling should therefore be rated as a two-leg sling.</p>		

Caution: 1. Refer to minimum radius.

2. Refer to included angle chart.

3. With double wrap ensure the sling does not cross under the load.

Note: Always hook from the inside.

(Visual inspection should be carried out prior to and during use at all times.)

Four-Leg Slings

Straight Lift

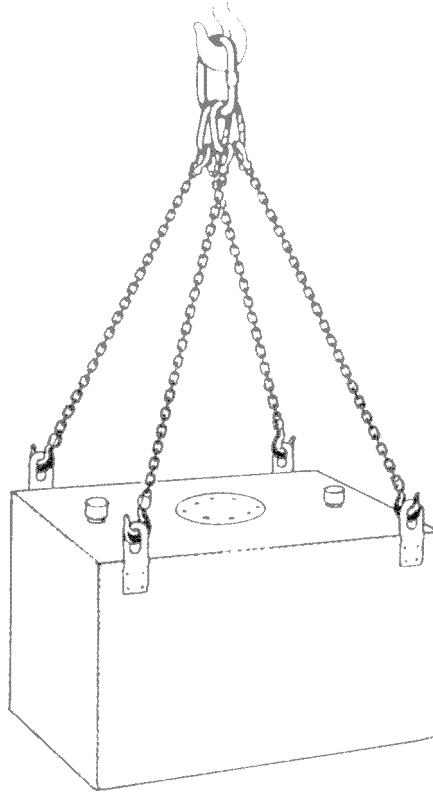

SWL: Rate as per load charts depending on included angle.

Comments: The included angle should be measured between diagonally opposite legs. Rate as indicated above only in cases where the load appears to be reasonably equally distributed between all four legs. If two legs are obviously supporting most of the load, rate as a two-leg sling. If three legs are obviously supporting most of the load, rate as a three-leg sling.

- Caution:**
1. Refer to minimum radius.
 2. Refer to included angle chart.

(Visual inspection should be carried out prior to and during use at all times.)

CRITERIA FOR SLING SELECTION

The Nature of the Load

With regard to the nature of the load, the aspects to be considered include the temperature of the load, the presence of sharp corners and polished surfaces. Rope or webbing is unlikely to be suitable for a hot load. If the load has sharp corners, chain might be more durable but, even so, edge protection will be necessary. If the load is polished or delicate in some other way, then man-made fibre webbing, a roundsling or fibre rope is likely to be best.

The Environment in Which the Sling Operates

If a corrosive environment is involved, e.g. use in a plating shop, then this is a complex problem and specialist advice should always be sought. It should also be remembered that laundries, swimming baths, pumping stations, sewage works, etc. can also give rise to corrosive conditions.

If outdoor use is involved, then natural fibre ropes are liable to rot and mildew and wire ropes to corrode. Marine conditions, atmospheric pollution, construction sites involving rock, mud, etc., will all aggravate outdoor environmental problems.

Handling of the Sling

Weight, flexibility, hand contact and length adjustment are some of the factors likely to be important when handling the sling. Fibre slings are lightest for a given lifting capacity and may be most suitable where frequent lifting and carrying of the sling is necessary. It should be remembered that chain and roundslings flex easily but cannot readily be pushed through a narrow gap whereas wire rope may. The effect of hand contact may be a consideration when handling the sling. Wire rope or chain is hard and cold to the touch whereas fibre is relatively larger in diameter (useful if pulling is involved) and warmer to handle. Wire rope is susceptible to broken wires.

Durability

Abrasion, storage, etc. will all influence durability. If abrasion is likely, then chain is most durable and fibre slings are most subject to abrasion damage. If storage for long periods between use is contemplated, a chain sling might be most suitable as other types are prone to various forms of deterioration unless stored under ideal conditions.

Stretch (Extension)

Synthetic ropes, flat web and round slings may be less suitable if stretch is likely to be a problem, e.g. for precise positioning.

(Visual inspection should be carried out prior to and during use at all times.)

USE OF SLINGS

The basic objective of good slinging practice must be to ensure that the load is safe and is as secure when slung in the air as it was on the ground.

Basic Principles

1. The sling and its method of use should be suitable for the load.
2. The method of attachment of the sling to the load and the sling to the lifting appliance should be secure.
3. No part of the sling should be overloaded either by the weight of the load or by the method of slinging.
4. The slinging method should ensure that the load is secure and that the load will not fall from the sling.
5. The load should be balanced and stable and should not violently change its attitude when lifted.
6. The load must not be damaged by, or cause damage to, the sling.

If any of the assumed conditions are not met, then it is possible that a large portion of the load will be imposed on only one, or at best, two legs of the sling. In such circumstances, it should be assumed that all of the load is being carried by one leg, so the sling should be de-rated accordingly as described in the example below by assuming that only one leg is in use. If a multi-leg sling is used with less than its actual number of legs attached to the load, then obviously the safe working load of the sling must be reduced. The amount by which it should be reduced can be calculated exactly but it is rather complex as a number of factors need to be taken into account, including the method of rating. An easy way of ensuring that the sling is never overloaded is to reduce the safe working load from that marked on the sling according to the number of legs in use.

Example: A four-leg sling with only two legs in use:

$$\text{Reduced SWL} = \frac{2}{4} \text{ i.e. } \frac{1}{2} \times \text{SWL marked}$$

A three-leg sling with only two legs in use:

$$\text{Reduced SWL} = \frac{2}{3} \times \text{SWL marked.}$$

N.B. The above only applies to the 4- or 3-legged rating, NOT the single-leg rating.

This inevitably means that, in some cases, the sling will be under utilised. If maximum utilisation is required, then reference should be made to a person who understands the factors involved and can therefore perform the necessary calculations.

(Visual inspection should be carried out prior to and during use at all times.)

SOME ESSENTIAL PRECAUTIONS

Before Lifting the Load

The weight of the load should be ascertained before lifting. The lifting method selected should be suitable for the load. The sling should be strong enough for the load, both in terms of its safe working load and its actual condition. The sling should be carefully inspected for obvious defects before use.

The load should be secure, stable and balanced when lifted. This requires an assessment of the position of the load's centre of gravity to ensure that the lifting point is approximately over it. Failure to do this assessment is likely to cause the load to swing wildly on being lifted, or even to fall out of the sling.

Any loose parts of the load should be adequately secured.

When Fitting the Sling to the Load

The sling must be firmly secured to the load, e.g. by means of hooks on to purpose-designed lifting points eyebolts, etc. or by a suitable method of slinging. The sling must not be twisted, knotted or kinked in any way nor should the lifting points be overloaded by the slinging method. The rated included angle of 120° must not be exceeded and the angle at any choke must not exceed 120° or at any basket should not exceed 120° .

When using three- or four-leg slings with out-of-balance loads or with unequally spaced legs, two legs may support the majority of the weight while the other leg or legs merely act as a balancer. If the lifting points on the load are not in the same horizontal plane the load, if it is flexible enough, will distort to accommodate the equal leg lengths of the sling. Alternatively, if the load is rigid, two legs will be likely to support the majority of the weight and may be overloaded while the remainder provide the balancing load. It is essential that any sharp corners on the load are adequately packed by dunnage, etc. to prevent damage to the sling.

RATING

In order to determine the size and configuration of sling necessary to lift any given load, users should appreciate the difference between working load limits and safe working loads and how these important limits are arrived at.

The Working Load Limit (WLL)

The working load limit is the maximum load (mass) that an item of lifting equipment is designed to raise, lower or suspend. In some standards and documents, WLL is referred to as 'maximum safe working load'.

(Visual inspection should be carried out prior to and during use at all times.)

The Safe Working Load (SWL)

The safe working load is the maximum mass which may be raised, lowered or suspended under specific service conditions. The onus is on the user to obtain a competent person's assessment of a SWL in the light of that person's knowledge of the particular conditions of service. Under normal service conditions the SWL will be the same as the WLL. If service conditions are liable to be hazardous, for example, extremes of temperature, possibility of severe shock loading, lifting loads across public roads or footpaths, or if the load is inherently dangerous such as acid or molten metal, the competent person must fix a SWL less than the WLL, the degree of de-rating depending upon the degree of potential hazard.

The rating recommendations given in the following tables are working load limits and are subject to reduction by the competent person who certifies a sling.

There are basically two methods of arriving at working load limits for chain slings although variations on these two methods are possible.

The Trigonometric Method

This is the traditional method used in New Zealand. Its advantage is its familiarity. Most slingers will be acquainted with the load charts which are an essential part of this method, and this is the rating system which is currently recommended in this code.

The theory behind this method is based on simple mathematics. The SWL of a multi-leg sling is calculated from the force induced into the legs of the sling by virtue of the mass of the load and the angle of the legs to the vertical.

The Uniform Load Method

It has been proposed that a simpler method of rating slings than that outlined above would be preferable. It is argued that slingers sometimes do not have the time or inclination to consult tables although this argument is largely answered by the use of pocket load tables. Undoubtedly the trigonometric method requires the slinger to be practised in estimating included angles whilst the uniform load method only requires a slinger to be able to recognise two included angles of 90° and the overall limiting angle of 120°. It must be said that the uniform load method makes greater provision for accommodating unequal loading of the legs of a multi-sling in that in most cases, though not all, this method produces a lower SWL than the trigonometric method.

The uniform load method proposes a fixed relationship between the SWLs of single-leg and multi-leg slings according to the following table:

(Visual inspection should be carried out prior to and during use at all times.)

Single-leg	Two-leg Included angle	Two-leg Included angle	Three- and Four-leg included angle	Four-leg Included angle
	0° - 90°	90° - 120°	0° - 90°	90° - 120°
1.0	1.4	1.0	2.1	1.5

A multi-leg sling, therefore, has only one SWL applicable to all included angles up to 90° and the SWL is stamped on the sling itself thus obviating the use of tables. For use at angles greater than 90° and up to 120° a second, lower SWL is allocated and stamped on a 'tab' which is affixed to the sling.

Whichever rating method is used, multi-leg slings **MUST NOT** be used at an included angle greater than 120°.

GOOD SLINGING PRACTICE

The safe and competent use of lifting gear cannot be adequately learned from a code. A good rigger learns their trade only after practical training and lengthy experience. However, this section establishes some sound basic principles and highlights some of the major malpractices which must be avoided.

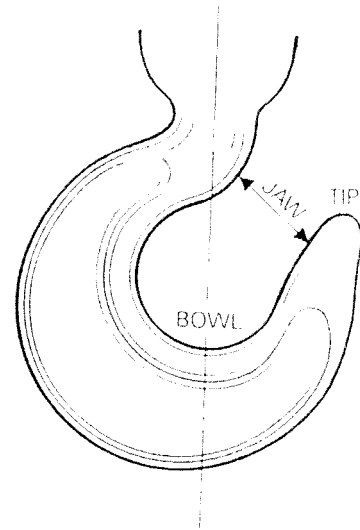

Tip Loading of Hooks

All hooks are designed to support the load in the bowl. Users should ensure that the hook of a sling engages freely in the lifting point so that the weight of the load is supported in the bowl of the hook.

Wedging or forcing the hook tip into the lifting point results in the hook being stressed in a manner for which it was not designed which may easily lead to hook deformation and premature failure.

Misuse of Shortening Clutches

Clutches can be misused. Ensure that the chain carrying the load always leads out of the bottom of the clutch as illustrated. If the direction is reversed so that the load carrying chain leads out of the top of the clutch, this can result in the front portion of the clutch being pulled off and the load being released.

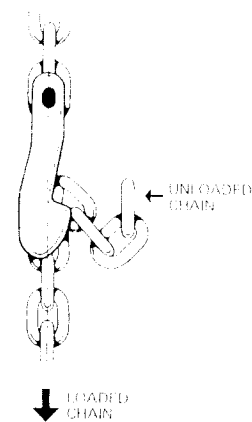

(Visual inspection should be carried out prior to and during use at all times.)

Knotting and Twisting and Transverse Bending of Chain

Chain is designed to support a load in a straight line with the line of force running through the crowns of each link. Chain which is twisted or worse, knotted, cannot develop its full strength and will almost certainly fail prematurely. Users should remove twists from a chain leg before lifting and should NEVER knot a chain. If it is necessary to shorten a chain, a shortening clutch should be used.

Similarly, chain which is bent under tension around a corner is stressed in a manner for which it is not designed. The user should use timber (or other suitable material) packing pieces to reduce the severity of this type of stressing. Refer to figure ## on page ##.

Load Stability

Good riggers will develop the habit of assessing usual loads and estimating the centre of gravity and then attaching the sling in such a manner that the centre of gravity is below the lifting points, or if this is impossible, well within them. If there is the slightest doubt of the stability of a load, it should be slowly lifted just clear of the ground. If the load tilts, the sling should be refixed in a more stable position.

CAUTION: HAMMERING DOWN IS DANGEROUS

It is sometimes imagined that slings in choke hitch can be made more secure by striking the hook or link or adjacent chain in an attempt to force the bight into closer contact with the load. This dangerous malpractice is often known as 'hammering down'.

The bight should be allowed to assume its natural angle, but should not exceed 120°.

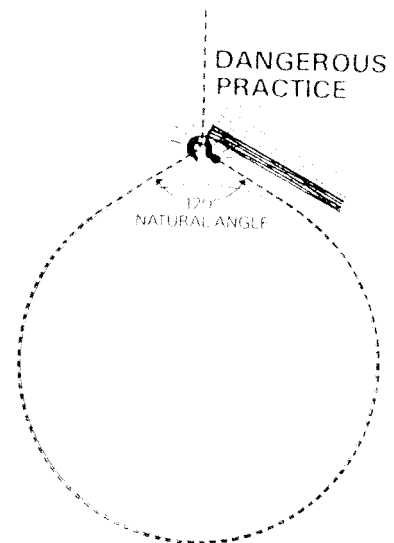

CARE IN THE USE OF ALLOY CHAIN SLINGS

Alloy chain slings sometimes have to be used in conditions which are potentially dangerous. Whilst such conditions may be avoidable, users should remain keenly aware of the penalties for carelessness and take every possible step to reduce the danger.

The user should make quite certain that potentially dangerous conditions are taken fully into account in choosing a sling of adequate size.

In particular, the user should bear the following in mind:

(Visual inspection should be carried out prior to and during use at all times.)

High Temperature Conditions

The strength of all alloy chain slings is adversely affected at elevated temperatures. If, therefore, slings are used in direct contact with, or in close proximity to high temperature loads, the SWL must be reduced as follows:

Chain Temperature	Reduction in SWL
Up to 200°C	Nil
200°C to 300°C	10%
300°C to 400°C	25%
over 400°C	Do not use

If it is suspected that a sling has been exposed to temperatures above 400°C, the sling should be referred to a competent person for a decision on its suitability for further use.

Low Temperature Conditions

Slings are perfectly safe at temperatures as low as -30°C. Do not use slings below this temperature.

Acidic Conditions

Slings are not recommended for use in acidic environments, whether immersed in acid solutions or used in atmospheres in which acid fumes are present. Steel of the type used in slings is vulnerable to hydrogen embrittlement when exposed to acids. Retaining pins being hollow and thin walled are quickly attacked by acids.

Compression Loads

High included angles increase compression forces on the load being lifted. Ensure that the load being lifted is capable of withstanding these forces. If in doubt, decrease your sling angle or use alternative methods.

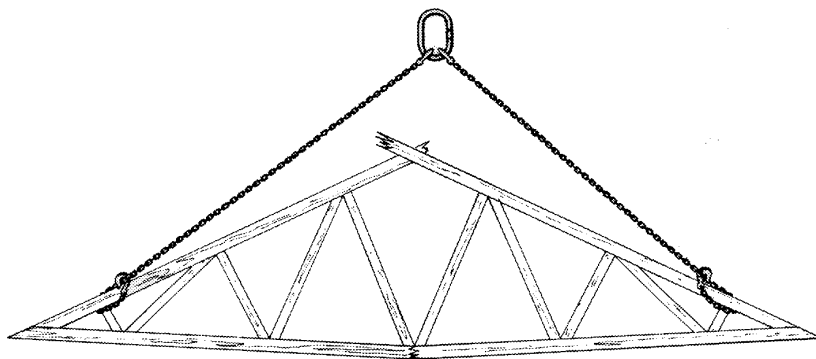

Shock Loading

Shock loads may break your slings even though the weight of the load being lifted is well below the working load limit for that sling. High acceleration forces or shock loads may be caused by the sudden operation of the crane by not taking up slack before starting to lift or by the sudden impact of falling loads.

(Visual inspection should be carried out prior to and during use at all times.)

Tag Lines

When lifting long loads, particularly in confined spaces, riggers should attach a rope or 'tag line' to one or both ends of the load so that rotational movement may be controlled.

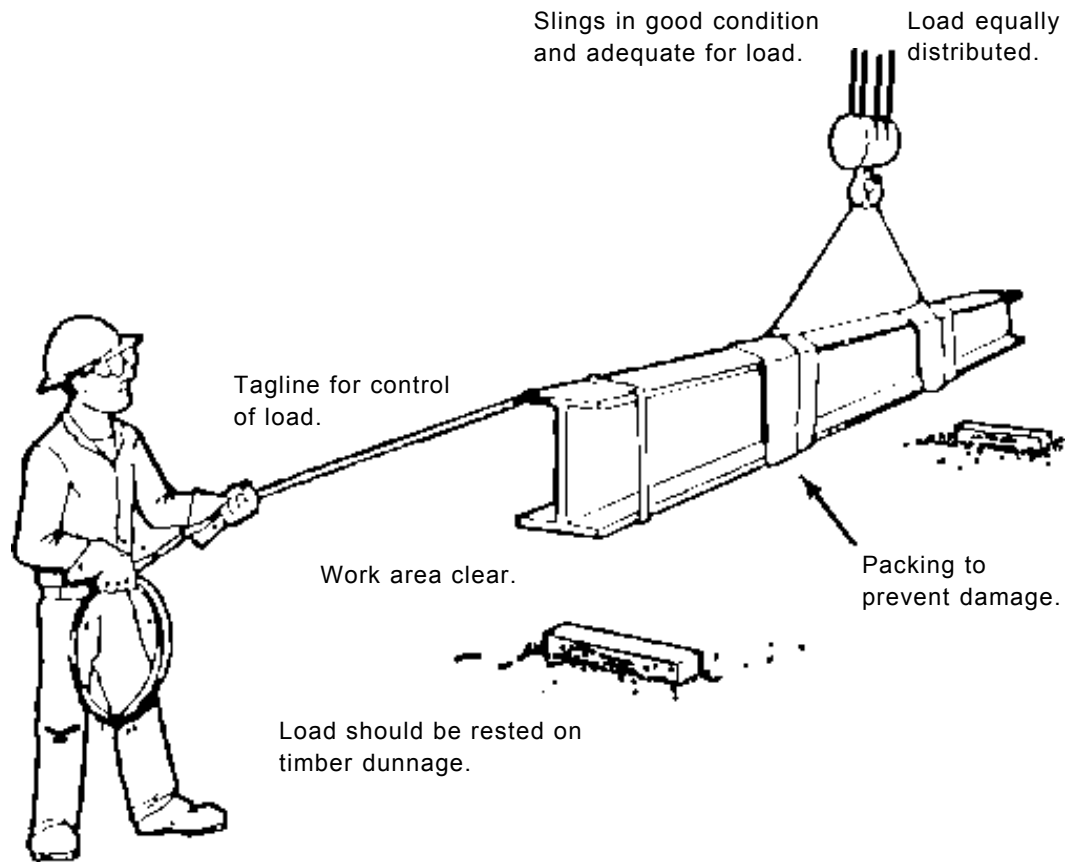

Hand Signals

Riggers and crane operators should use the hand signals shown in the *Approved Code of Practice for Cranes* and the Power Crane Association safety manual.

Before lifting operations are commenced there should be an agreement between the crane operator and the riggers that only one rigger is in charge of a lift and only that person will give signals. The crane operator should ignore signals from all other personnel except the EMERGENCY STOP signal which may be given by anyone present and must always be acted upon.

Landing the Load

Before a load is lifted, a place should be prepared where it is to be put down. The nature of the load will determine the type of preparation necessary but most loads should be lowered onto timber battens. The sling may then be easily withdrawn. The load should never be landed directly on to the chain.

(Visual inspection should be carried out prior to and during use at all times.)

Radio Communication

Use and Care of Radios

The use of two-way radios for communication in the crane industry has become an essential part of day-to-day lifting operations.

Radios would normally be used in one or more of the following situations:

- Where the load being lifted is not visible to the crane operator and/or dagger; or
- Where hand signals may not be clearly seen because of:
 - Height of load;
 - Height of lift;
 - Distance;
 - Obstructions and site conditions;
 - Weather conditions; or
 - Multiple lift operations.

Persons using two-way radios for communication should be familiar with the manufacturer's operating instructions.

In the interests of safety the following recognised standard procedures **MUST** be followed when radios are in use:

- Prior to commencement of any task on site the radios to be used **MUST** have an operating safety check to ensure they are performing satisfactorily and the battery is charged. A spare battery should be available.
- A dedicated channel should be used for each lifting operation. Check for other radios in use on the site.
- Operators should familiarise themselves with any particular worksite procedures regarding the use of radio communication on that particular site.
- A constant talk method should be adopted requiring the radio users to talk in such a manner that the progress of the task is continuously made known to people involved at all times.
- To eliminate any misunderstanding crane operators should normally take radio instructions from one competent person only. Special circumstances may require specific arrangements to be put in place when using more than two radios.
- To ensure reliable and prolonged service all radios **MUST** be kept fully charged, dry and handled with care.

All crane operations **MUST** cease immediately if any loss or deterioration of radio communication occurs.

Be aware of interference and signals from other radio users.

(Visual inspection should be carried out prior to and during use at all times.)

Hooking Back Unused Legs

In the case of multi-leg slings with not all legs in use, the unused legs should be hooked back by engaging the hook in the master link or the quadruple master assembly. Similarly, after finishing a lift, if the sling is to remain on the crane hook, all hooks should be hooked back into the master link or the quadruple master assembly.

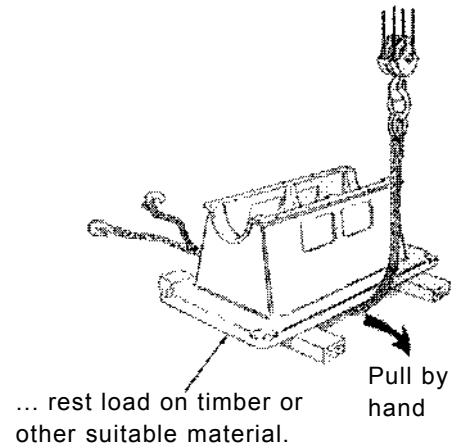

Sling Stowage

When lifting operations are finished, slings should be removed from crane hooks and stowed on a properly designed rack. They should not be left lying on the floor where they may suffer mechanical or corrosion damage or may be lost.

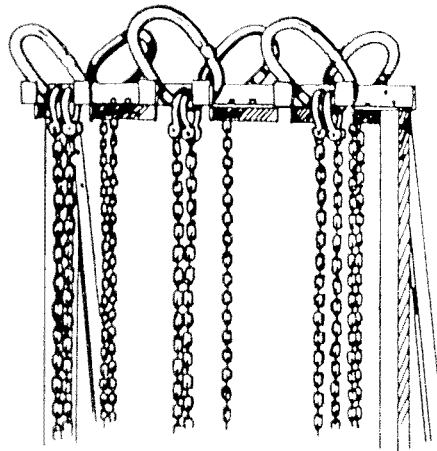

CARE IN THE USE OF FLAT WEB AND ROUND SLINGS

Flat web and round slings can be easily damaged.

Avoid:

- Overloading
- Contact with sharp edges
- Exposure to heat
- Chemical solutions (unless manufacturer's instructions allow)
- Grit or abrasive materials (**Caution:** grit can get into and under wear sleeves).

(Visual inspection should be carried out prior to and during use at all times.)

Never:

- Tie knots in slings;
- Use a sling when the SWL cannot be positively identified (SWL tags or manufacturer's colour/stripe identification).

Always make sure you identify the load rating for the sling.

Note: A nylon sling's load rating is reduced by 15% when wet.

CARE IN THE USE OF WIRE ROPE SLINGS

Avoid:

- Overloading slings;
- Contact with sharp objects;
- Dragging slings over abrasive surfaces;
- Distortion of eyes by use of small hooks or shackles;
- Passing the rope around small diameter turning points (including shackles or hooks);
- Using undersized slings; and
- Excessive wear.

Always make sure you identify the load rating for the sling.

6.8 WINCHES, SHEAVES AND PURCHASES FOR FLEXIBLE STEEL WIRE ROPE

SHEAVES

Sheaves lead the rope over the head of cranes and hoists and are used in pulley systems to gain a mechanical advantage.

Flare Angle and Groove Depth

The groove depth of a sheave should not be less than 1.5 times the rope diameter. However, if the rope is positively prevented from leaving the groove, the minimum depth of the groove can be equal to the rope diameter.

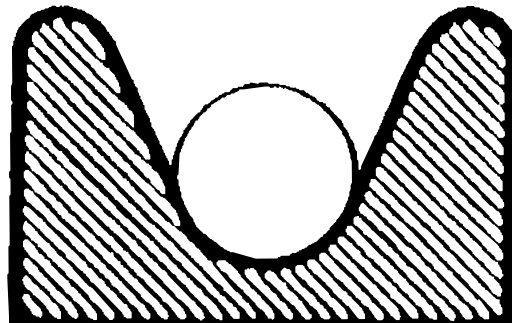

(Visual inspection should be carried out prior to and during use at all times.)

The sheave groove sides should have a flare angle of a minimum of 42° and a maximum of 52°.

The grooves should be slightly larger than the nominal diameter of the rope. Grooves which are too large will flatten the rope. Grooves which are too small will pinch the rope and the extra friction can cut it to pieces.

Sheaves should have a smooth finish with flared edges which are rounded-off.

Sheave Diameters

Caution: Modern cranes and hoists are examples of complex engineering equipment, and many have special construction luff and hoist ropes. It is essential that the sheaves which were designed for a particular crane or hoist are used for that purpose.

It is also essential that when a rope is replaced, the replacement is the same diameter and of suitable construction and that the sheave system is thoroughly checked to ensure that any damaged or worn grooves likely to ruin the new rope are repaired or replaced.

RECOMMENDED MINIMUM SHEAVE DIAMETERS FOR MAXIMUM ROPE LIFE – MULTIPLE OF ROPE DIAMETER

Rope	Construction	Multiple
6x7	6/1	43
6x19	12/6/1	26
6x19s	9/9/1	32
6x24	15/9/F	22
6x25	12/6+6F/1	26
6x31	12/6 and 6/6/1	25
6x41	16/8 and 8/8/1	20
18x7	6/1	32
34x7	6/1 NR	23

Formula: Recommended sheave diameter = rope diameter x multiple.

REEVING

Large capacity cranes have several parts to the main hoist fall making the main hook very slow.

When reducing the number of parts to give a faster hook, ensure that the

falls are not reduced from one side of the boom head sheaves and the main hoist block.

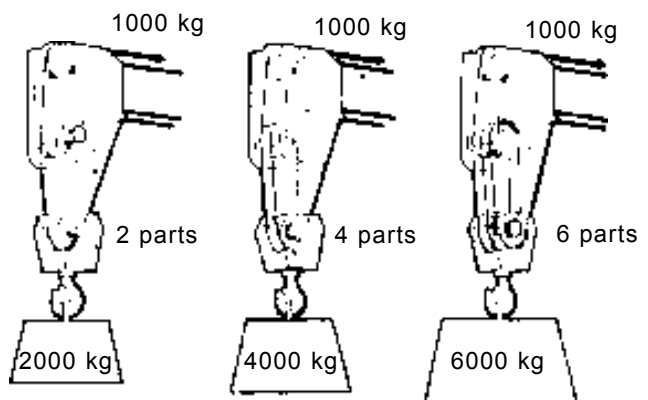

(Visual inspection should be carried out prior to and during use at all times.)

Otherwise rotational torque can develop on the boom head exerting side pull on the main hoist block. When reducing parts, the rope must be reeved again to ensure that there are an equal number of parts either side of the boom head and the main hoist block.

The number of parts must be capable of supporting the load to be lifted. A fast hook must still be a safe hook.

Inspection

Sheaves should be inspected regularly. Pay particular attention to the sheave groove and flange. Any cracks or chips on the flange can cut the rope as it lays into the groove.

The groove should be checked for wear which will result in the reduction of the groove diameter and give an uneven bearing surface for the rope.

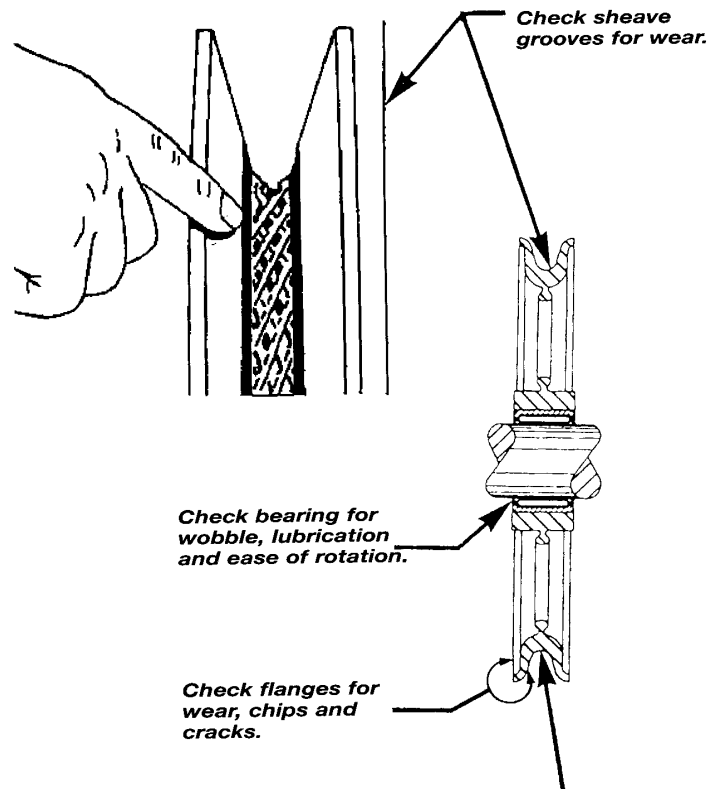

All sheaves should be checked for lubrication. Badly lubricated sheaves cause extra friction in the system and wear on the sheave pin and bearing.

The pin should be prevented from rotating with the sheave. Some sheave pins only have a small cotter pin which fits into a recess on the cheek plate. The cotter pin sometimes shears and allows the pin to turn with the sheave. Rotating pins are dangerous as they turn and can cut through the cheek plate.

A 'jockey sheave' is sometimes used as the first diverting sheave to reduce the flare angle.

(Visual inspection should be carried out prior to and during use at all times.)

This sheave fits on an extended pin to allow it to slip from side to side reducing the flare angle. The jockey sheave pin should be kept well greased and free from grit and dirt to allow the sheave to slide across the pin.

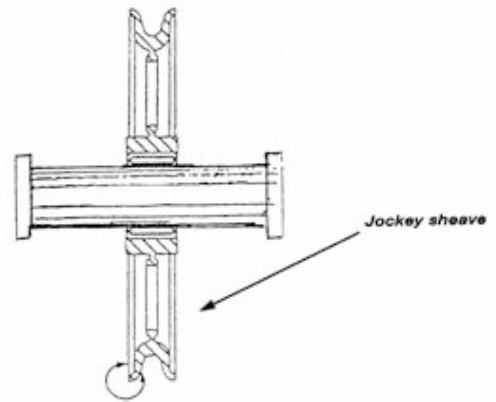

Drums

Drums are the pulling mechanism which rotates, hauls in and stores surplus wire. The braking mechanism is connected to either the drum or the gearing which is joined to the drive mechanism.

The rope should lay neatly on the drum and not be bunched up. There should be a minimum of three full turns on the drum at all times.

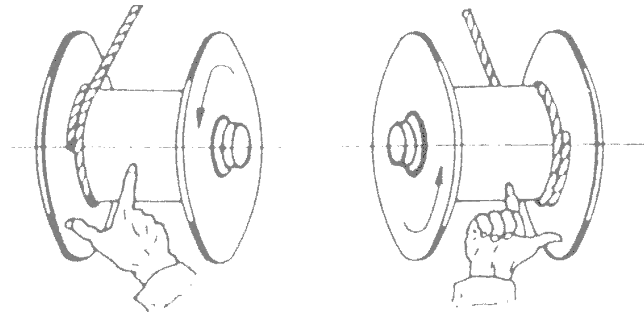

(a) RH lay rope overwound

(b) RH lay rope underwound

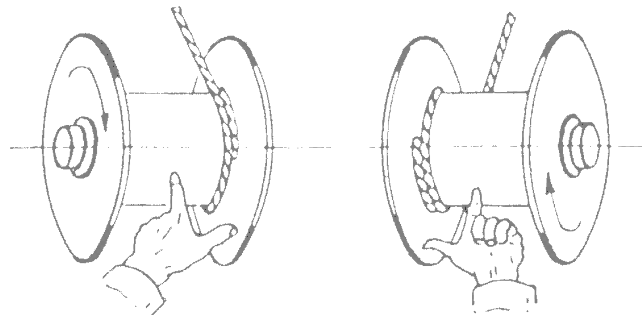

(c) LH lay rope overwound

(d) LH lay rope underwound

The rope must be anchored to the drum with a fixed mechanical anchorage. Be aware of the danger of not properly tightening an anchorage. Do not rely on the frictional grip relayed by the 3 turns on the drum.

Comply with the manufacturer's recommendation about whether drums are overwound or underwound. If a drum is wound up incorrectly, it can affect the anchorage, brake and drive mechanism to the drum, resulting in mechanical failure.

(Visual inspection should be carried out prior to and during use at all times.)

The lay of the rope and whether the drum is overwound or underwound determines where the rope is to be anchored.

Be especially careful when raising very heavy loads to a great height, such as with long boom mobile cranes. The amount of turns on the drum determine the drum diameter. As the diameter increases, the torque to the drive mechanism and brake increases. As a result the higher the load is raised the faster it is raised, and the more difficult the load is to control.

The top layer on a multi-layered drum must not be closer than the manufacturer's recommendation to the top of the flange when the drum is full.

Fleet Angles

The maximum fleet angle is measured from the centre of the drum to the centre of the first diverting sheave then back to the inside flange at the middle of the drum.

The maximum fleet angle for a grooved drum is 5° and for an ungrooved drum is 3°. To achieve these angles the distance from the drum to the first diverting sheave must be a minimum of:

- 19 times half the width of the drum for an ungrooved drum.
- 12 times half the width of the drum for a grooved drum.

Example 1:

Width of the grooved drum = 1 metre

$$12 \times 1 \times 0.5 = 6$$

Therefore, the sheave must be 6 metres from the drum.

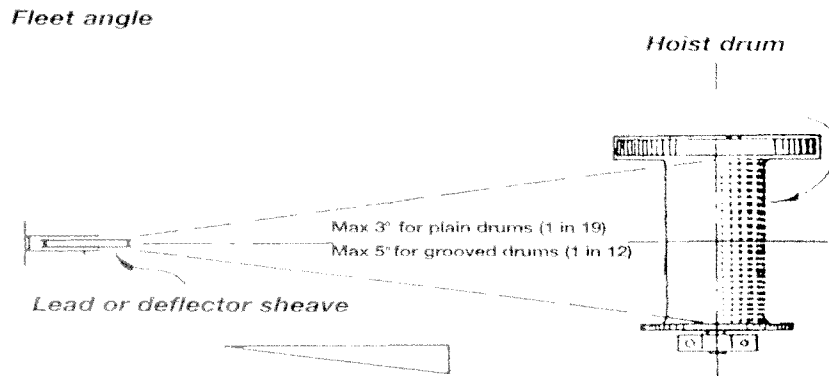

Example 2:

Width of the ungrooved drum = 1 metre

$$19 \times 1 \times 0.5 = 9.5$$

Therefore, the sheave must be 9.5 metres from the drum.

If the fleet angle is too large or the distance between the drum and the first lead or diverting sheave is too short, the rope will not lay neatly on the drum and will create severe wear on the rope and the sheave flange.

(Visual inspection should be carried out prior to and during use at all times.)

SAFE LOADS ON WIRE ROPE PURCHASES OF A TEMPORARY NATURE

When the fleet angle is too large

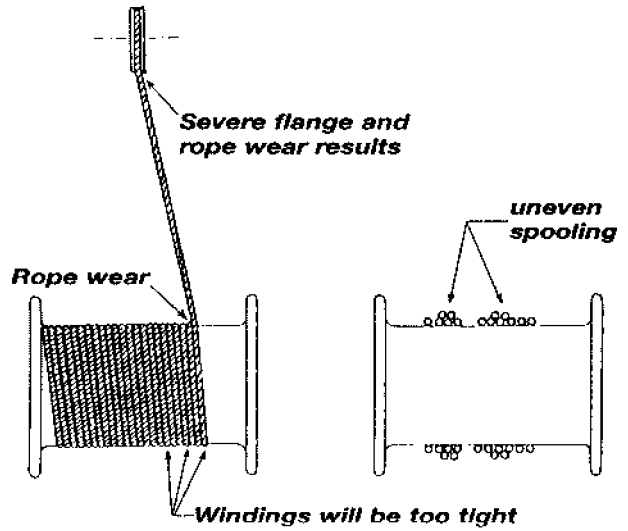

When the fleet angle is too small poor spooling results

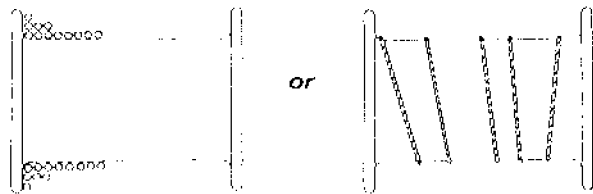

Effect of fleet angle on spooling

The figures in each diagram indicate the number of running sheaves in each pulley block.
 Tabulated safe loads allow for an extra (lead) sheave (not shown in diagrams).
 P = Pull in the lead rope (as fixed by the size of the rope) - t
 D = Minimum diameter at bottom of groove of sheave - mm
 W = Safe load that may be lifted.
 Parts of rope supporting load - tonnes
 Rope
 Size Diameter
 mm

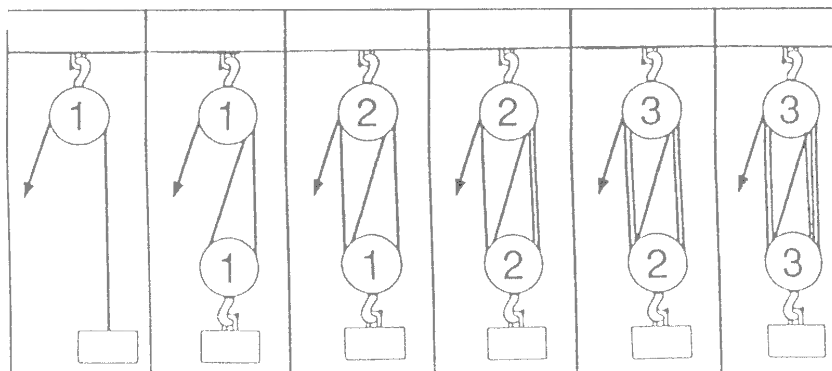

(Visual inspection should be carried out prior to and during use at all times.)

D mm P T	Parts of Rope	Supporting Load -	Tonnes W					
			1	2	3	4	5	6
8	120	0.825	0.790	1.542	2.26	2.96	3.62	4.26
9	135	1.03	0.988	1.93	2.83	3.69	4.52	5.31
11	165	1.55	1.48	2.89	4.26	5.56	6.80	8.00
13	195	2.16	2.05	4.04	5.94	7.75	9.48	11.15
16	240	3.28	3.11	6.13	9.02	11.77	14.40	16.92
19	285	4.62	4.39	8.63	12.70	16.58	20.28	23.83
20	300	5.14	4.88	9.61	14.13	18.45	22.56	26.52
22	330	6.20	5.89	11.59	17.05	22.26	27.22	32.00
26	390	8.66	8.22	16.19	23.81	31.09	38.02	44.68
28	420	10.06	9.56	18.81	27.66	36.11	44.16	51.90
32	480	13.14	12.48	24.57	36.13	47.17	57.68	67.80

Based on bronze sheaves for friction loss.

Note: The above masses must not exceed those marked on the blocks as being the safe mass that may be lifted. Most blocks are limited by the size of hooks and other components and not the number of falls of rope. A factor for friction has been added.

1. The working load limit together with any conditions of loading deemed necessary for safe use is to be stamped or otherwise marked on each block.
2. Sheave diameters measured at the bottom of the groove may be as follows (temporary use only):
 - (a) For power-operated blocks: 15 x rope diameter.
 - (b) For hand-operated blocks: 10 x rope diameter.

Purchases

A wire rope reeved through sheaves to obtain a mechanical advantage is known in rigging as a 'purchase'.

Purchase and lead blocks should have the close fitting cheeks pattern, or be the dished type where the sheave is recessed into cheeks.

Snatch Blocks

Snatch blocks should always be carefully watched, the gate must be properly closed and the split pin inserted and split open.

Snatch blocks should incorporate a locking pin of positive type not requiring the use of any tool for its effective positioning. A drop nose pin used as a hinge pin is recommended and the locking device must be strongly made and suitable for the intended use of the block.

Sheave Blocks

Twisting would cause the rope to jam or ride on the rim of the sheave, and slip between the sheave and the cheek plate, jamming and destroying the rope.

(Visual inspection should be carried out prior to and during use at all times.)

Reverse Bends

Avoid reverse bends because they cause much greater fatigue than if all bends were made in the one direction.

A rope running in one direction over one sheave and then in a reverse direction (i.e. 'S' fashion) over another sheave will suffer early fatigue and deterioration. As the rope passes over a sheave it is bent, and as it leaves the sheave it is straightened, two distinct actions causing fatigue. This is made worse if the rope, after being bent in one direction, is then straightened and again bent in an entirely opposite direction over another sheave after which it is again straightened.

Multiple Layers on Drums

If a load is to be lifted to a height where multiple layers must be laid onto a drum, there are several safety precautions that should be taken.

Independent steel wire cored ropes should be used to prevent crushing.

The drum must have the capacity to take the amount of rope. The bottom layers must be tightly and neatly laid onto the drum.

The Capacity of Drums and Storage Reels

There is a formula for determining the amount of rope that can be stored on a storage reel. This formula can be used when determining whether the winch drum has sufficient capacity to take the amount of rope needed in a purchase.

Length of rope that can be stored on a reel/drum/barrel

$$\text{Capacity } L \text{ in metres} = (A + D) \times A \times C \div 1000 \times K$$

Where, L = Length of rope in metres.

A = Depth of reel/drum/barrel flange in mm

D = Diameter of reel/drum/barrel in mm

C = Distance between flanges in mm

K = A multiplying factor for various rope diameters (see table).

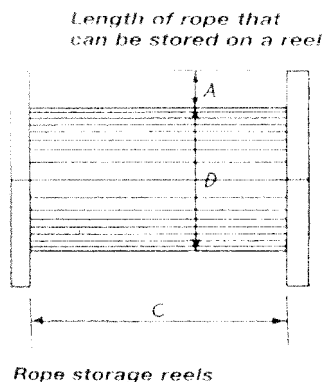

(Visual inspection should be carried out prior to and during use at all times.)

Rope Diameter mm	Multiplier 'K'	Rope Diameter mm	Multiplier 'K'
6	11.2	36	400
10	31	40	500
12	45	44	600
16	80	48	720
20	125	52	840
24	180	56	980
28	240	60	1120
32	315	-	-

Alternative Method

$$\text{Rope Length (m)} = \frac{(A+B) \times A \times C \times \mu \times 10^6}{D^2}$$

Where A, B and C are quoted in metres and D in millimetres.

CABLE PULLING STOCKINGS

Cable pulling stockings are used for reeving wire ropes through purchases and for fitting cables in various places where the opening or access is restricted.

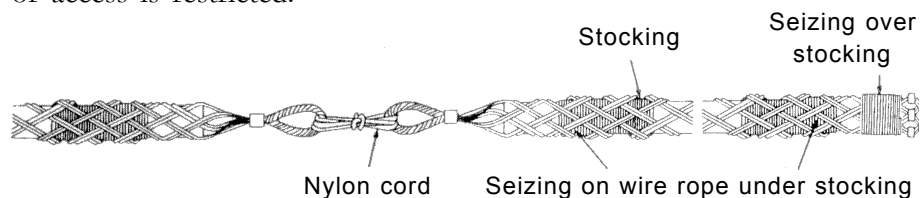

They are especially useful where the boom head, luff drum, and hoist winch of tower cranes are high above the ground.

A fibre rope is reeved and attached to the drum, and then is attached to the rope which is fitted with a cable pulling stocking. The rope is then pulled through the system by the fibre rope.

Cable pulling stockings must not be used for load lifting purposes.

SEIZINGS

It is most important that tight seizings of annealed iron wire or strand be maintained on the ends of ropes whether preformed or not. If ropes are not properly seized prior to cutting, wires and strands are apt to become slack with consequent upsetting of uniformity of tensions in the rope. This could result in overloading of some wires and strands and underloading of others, leading to the occurrence of high strands, bird caging of wires, or breakage of wires and strand.

Rotation resistant ropes, regardless of their construction, depend on retention of built-in torsional balance for their ability to resist rotation under load. Therefore, it is essential that the seizing

(Visual inspection should be carried out prior to and during use at all times.)

practice as described below and in the accompanying diagram be carefully followed.

Seizing Rotation Resistant Ropes

Ropes must be served tightly on each side of the position where they are required to be cut. The length of each serving should be equal to two rope diameters. For multi-strand and rotation resistant ropes, two servings on each side of the cut are recommended and after cutting, the rope end must be welded up across its section so that all the wires and strands are completely secured.

It is recommended, where possible, that the rope be fused and tapered by the supplier.

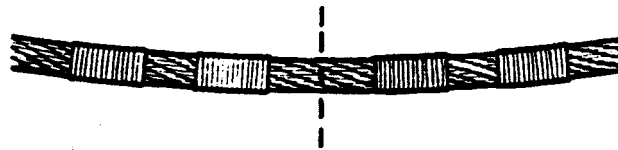

TENSION IN EACH SLING LEG

N.B. The greater the included angle of "A" the greater the load in the sling legs.

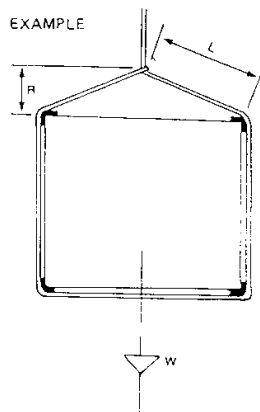

Example:

T = Tension in rope in each sloping leg.

L = Length of each leg.

R = Rise

W = Load to be lifted

$$T = \frac{1/2 W \times L}{R}$$

i.e. If, load = 2 tonnes

$$L = 675 \text{ mm}$$

$$R = 300 \text{ mm}$$

$$\text{then, } T = \frac{0.5 \times 2000 \text{ kg} \times 0.675}{0.3000}$$

$$= 2.25 \text{ tonnes}$$

therefore, because of reeving, select sling for:

$$2 \times 2.25 = 4.5 \text{ tonnes}$$

(Visual inspection should be carried out prior to and during use at all times.)

6.9 RIGGING BLOCKS

MULTIPLICATION FACTORS FOR SNATCH BLOCK LOADS

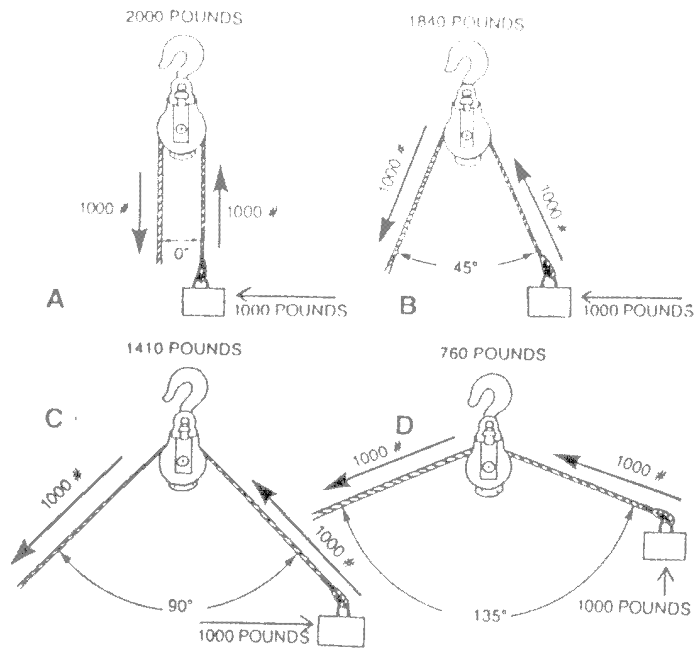

Angle Between Lead and Load Lines (°)	Multiplication Factor
10	1.99
20	1.97
30	1.93
40	1.87
50	1.81
60	1.73
70	1.64
80	1.53
90	1.41
100	1.29
110	1.15
120	1.00
130	0.84
140	0.68
150	0.52
160	0.35
170	0.17
180	0.00

(Visual inspection should be carried out prior to and during use at all times.)

HIGH LINE TENSION BY FORMULA

The total weight is the combined weight of the load plus the hoist line pull.

The tension formula is: $T_1 = \text{Load} \times D_2 S_1 / H(D_1 + D_2)$

$$T_2 = \text{Load} \times D_1 S_2 / H(D_1 + D_2)$$

(Use softeners when lifting from building structural steel)

High Line Formula Example

Weight = 3,000 kg Pull = 3,000 kg

Total load = 6,000 kg

$S_1 = 10.1$ $S_2 = 4.1$

$D_1 = 10$ $D_2 = 4$

$H_1 = 1$

$T_1 = \text{Load} \times D_2 S_1 / H(D_1 + D_2)$

$T_1 = 6,000 \times 4 \times 10.1 / 1(10 + 4)$

$T_1 = 242,400 / 14 = 17,314$

The left side tension is 17,314 kg

$T_2 = \text{Load} \times D_1 S_2 / H(D_1 + D_2)$

$T_2 = 6,000 \times 10 \times 4.1 / 1(10 + 4)$

$T_2 = 246,000 / 14 = 17,571$ kg

The right side tension is 17,571 kg

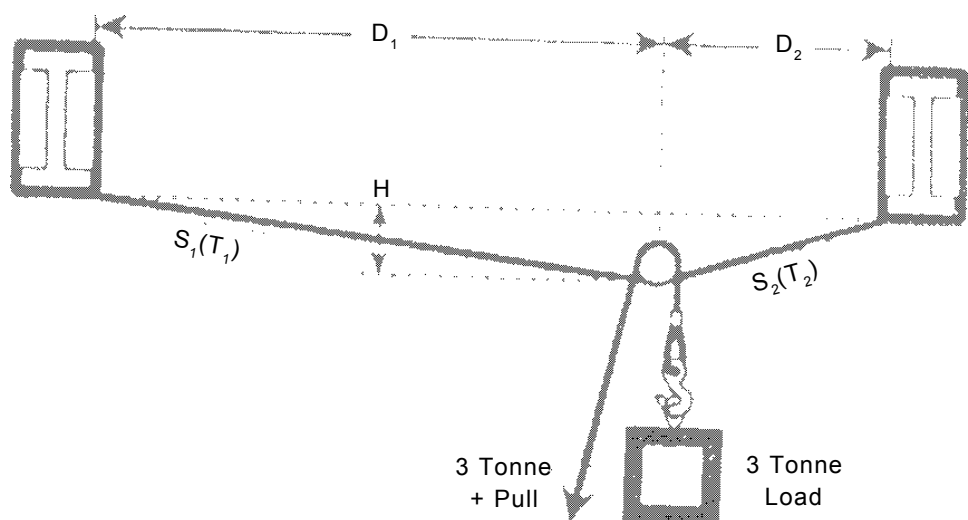

(Visual inspection should be carried out prior to and during use at all times.)

FALL TENSION FORMULA

The tension on two falls drifting a load can be enough to extensively overload them. Calculating the tension uses the same method as that used for a high line.

Fall (or come-a-long) tension will vary when a load is lifted, then drifted over to another location. The tension on each chain fall can be worked out by formula for various positions.

Example Tensions While Drifting a Load

$$T_1 = \text{Load} \times D_2 S_1 / H(D_1 + D_2)$$

$$T_2 = \text{Load} \times D_1 S_2 / H(D_1 + D_2)$$

Load on fall B (initial position 1) = 1000 kg

Load on fall A (final position 3) = 1000 kg

$$S_1 = 6.1S_2 = 12.3$$

$$D_1 = 3.8D_2 = 11.4$$

$$H = 4.7$$

$$\text{Fall A (position 2)} = \text{Load} \times D_2 S_1 / H(D_1 + D_2)$$

$$\text{Fall A} = 1000 \times 11.4 \times 6.1 / 4.7(3.8 + 11.4)$$

The tension on fall A = 69540/71.44 = 973 kg.

$$\text{Fall B (position 2)} = \text{Load} \times D_1 S_2 / H(D_1 + D_2)$$

$$\text{Fall B} = 1000 \times 3.8 \times 12.3 / 4.7 (3.8 + 11.4)$$

The tension on fall B = 46740/71.44 = 654 kg

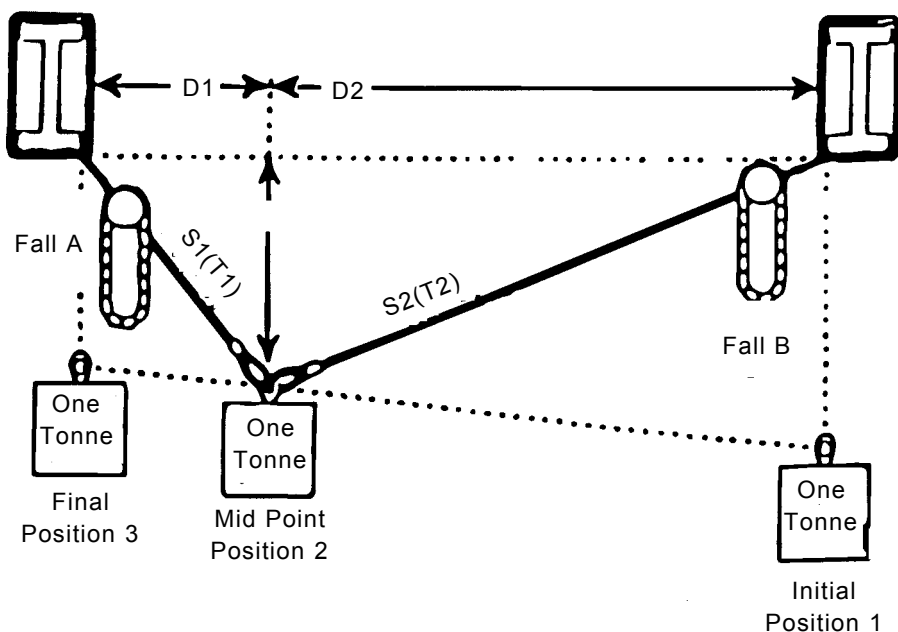

Note: The above formula is based on both falls being positioned at the same elevation.

(Visual inspection should be carried out prior to and during use at all times.)

6.10 HANDLING STEEL PLATE

Certified equipment should be used at all times.

Steel plate can be lifted with:

- Plate clamps that are designed to increase the purchase on the plate as the plate is lifted.
- Hooks or shackles where there are lifting holes in the plate.

Do not use home-made type plate clamps or plate dogs.

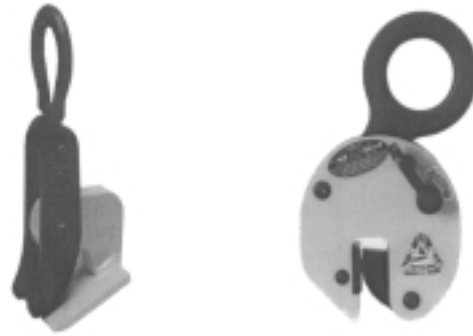

Examples of types of plate clamps

Plate clamps should be used as per manufacturer's recommendations, e.g. hardness of plate.

A spreader beam must be used if the angle between the two legs is likely to be more than 60°.

CONTAINER LIFTING CLAMPS (TWIST LOCKS)

These are to be used as per the manufacturer's recommendations.

PALLETS

A wide variety of loads are delivered on pallets. Before a palletised load is lifted from a truck, check that:

- The pallet is free from defects; and
- The load is secured so that nothing can fall off.

TURNING OVER LOADS

When turning over a load, such as a steel beam, the sling must be attached to the hook on the side of the load that is to be lifted. This will ensure that it will be raised on a diagonal through the centre of gravity.

It is then a simple matter to lower the hook, turning the beam over in a safe and controlled manner.

(Visual inspection should be carried out prior to and during use at all times.)

It is important that the beam is slung so that when the beam is lowered the nip will pull against the eye.

Structural steel members such as universal beams and RSJs have a high centre of gravity and a narrow base when standing on their flange. If a sling is nipped incorrectly the beam will flop, topple over and possibly break the slings.

The same principles apply when turning over all loads.

Correct Method of Turning Over a Load

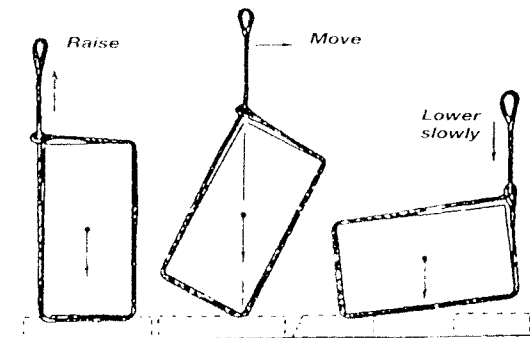

Correct Method of Turning Over a Steel Bin

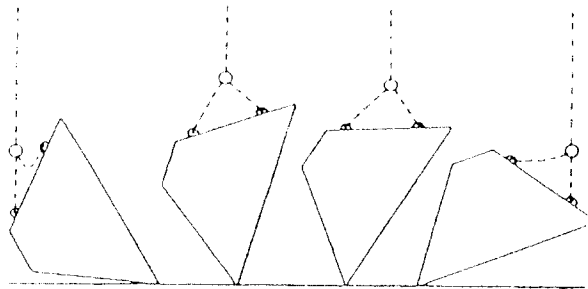

6.11 MOBILE CRANES ON SITE CONCRETE TILT SLAB (PANEL) ERECTION

In general, a tilt slab project should be set out for a particular crane in conjunction with the customer and site personnel before construction begins.

Ideally, a panel erection team should consist of four people plus the crane operator (2 prop men, 1 dogger/signalman, 1 positioner). The team must be briefed to ensure each member clearly understands what they are required to do.

Sling angles must NOT exceed 60°.

Know the panel weight before the lift.

Take great care when breaking away (debonding) from the casting bed/floor. Do NOT apply a crane load/force greater than 110% of the panel weight.

(Visual inspection should be carried out prior to and during use at all times.)

To minimise side loading of the boom the crane should be placed in a position so that the final tilting into position can be accomplished by hoisting and luffing rather than by slewing.

Wherever possible, tilt the top of the panel toward the crane.

CRANE WORKING RADIUS

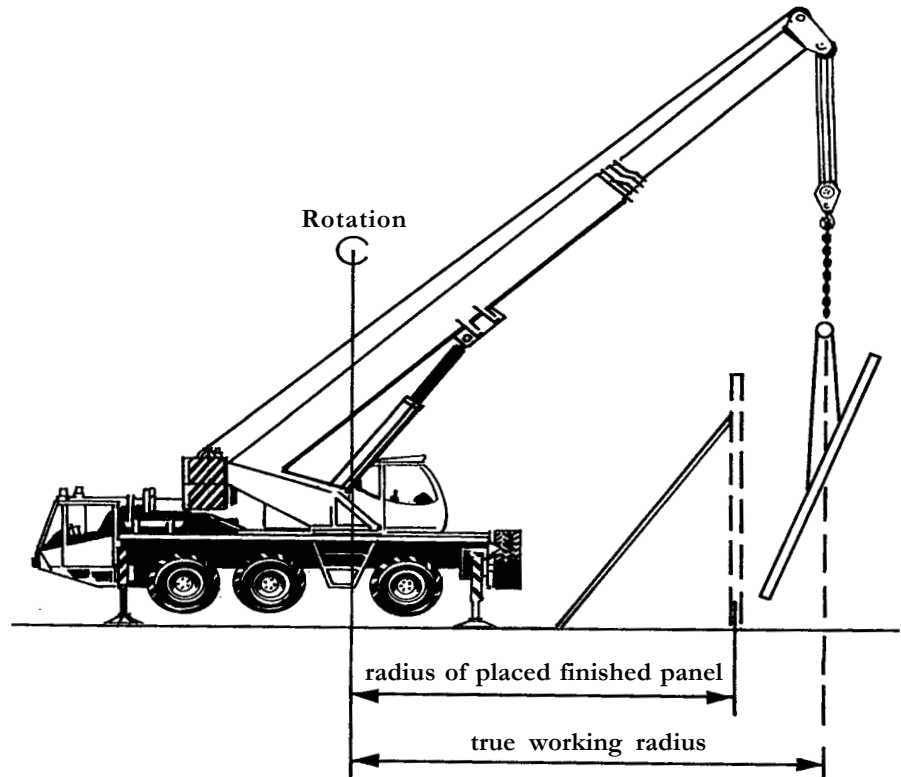

Note: The true working radius from the centre of rotation to the hook will depend on actual panel details.

Before the lift is attempted, care must be taken to ensure that the panel is rigged according to the design engineer's specifications.

Lifting eyes attached to the lift anchors must be the correct size and rating.

The spreader or lifting beam must be set correctly before the lift is attempted. Spreader lifting points are determined by the positions of the lift anchors.

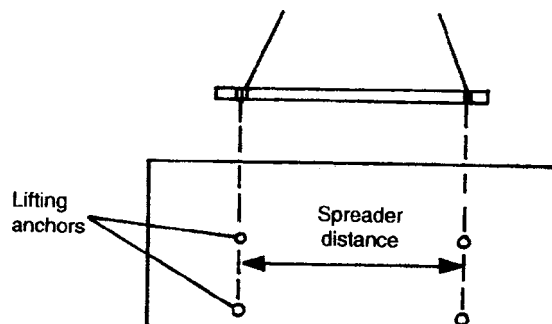

(Visual inspection should be carried out prior to and during use at all times.)

Props should be fitted securely to the panel and a person assigned to keep them clear of the ground as the panel is lifted into place. The prop feet must be secured once the panel is in place.

Temporary pins securely placed to the floor in the footing should be used to prevent the panel slipping and to assist it into place during the lift.

At no time should any personnel position themselves on the underside of the panel until it is securely in place.

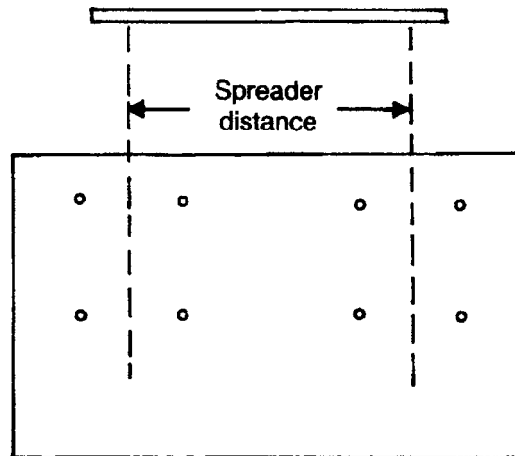

(Visual inspection should be carried out prior to and during use at all times.)

6.12 ON SITE CONCRETE TILT SLAB (PANEL) ERECTION

Proper planning of the lift configuration can determine the success of a tilt-up project.

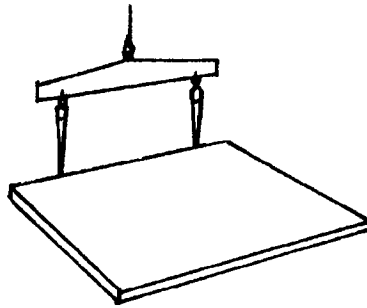

EDGE LIFT

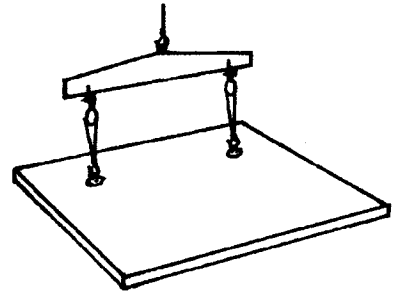

SINGLE ROW (2 POINT)

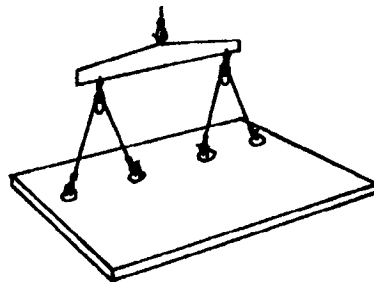

SINGLE ROW (4 POINT)

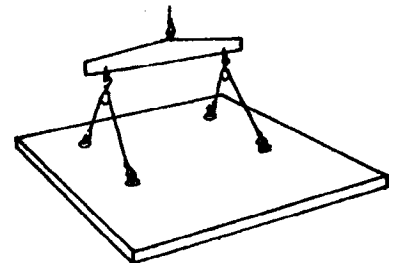

DOUBLE ROW

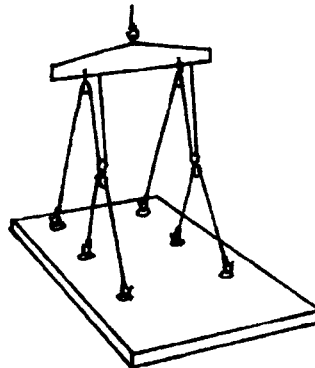

3 HIGH EQUAL LOAD

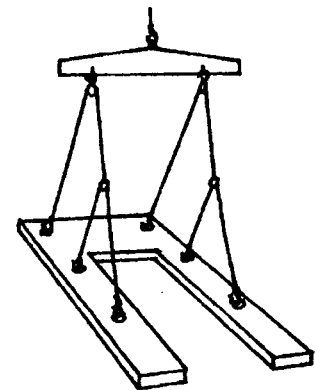

3 HIGH DOUBLE LOAD
(TOP ANCHORS)

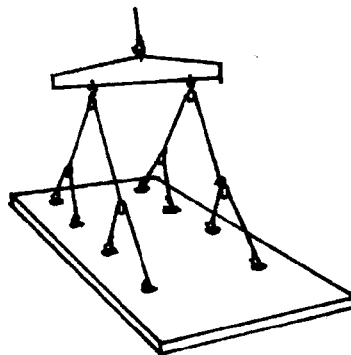

4 HIGH 2 WIDE

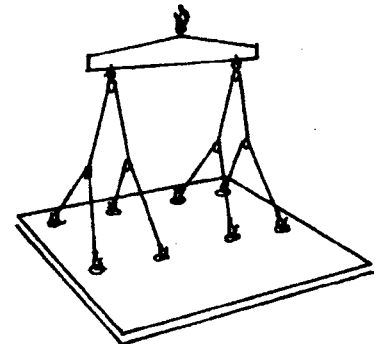

2 HIGH 4 WIDE

(Visual inspection should be carried out prior to and during use at all times.)

APPENDIX: REFERENCE DOCUMENTS

- Health and Safety in Employment Act 1992
- Health and Safety in Employment (Asbestos) Regulations 1998
- NZS5227 Specification for flat slings Part 2
- BS4942 Short link chain for lifting purposes
- ISO7593 Chain slings assembled by methods other than welding
- BS302 Stranded steel wire ropes
- ISO4309 Cranes - wire ropes - Code of practice for examination and discard
- BS464 Specification for thimbles for wire ropes
- DIN1142
- BS3032 Specification for higher tensile steel shackles
- Federal Spec RR271 Alloy hi-load standard shackles
- BS4429 Specification for rigging screws and turnbuckles for general engineering, lifting purposes and pipe hanger applications
- BS4018 Specification for pulley blocks for use with wire rope for a maximum lift of 25 tonf in combination
- BS4536 Specification for heavy duty pulley blocks
- NZS3404 Steel structures
- BS4278 Specification for eyebolts for lifting purposes
- BS3243 Specification for hand-operated chain blocks
- BS4898 Specification for chain lever hoists
- BSEN1677.5:2001 Components for slings. Safety. Forged steel lifting hooks with latch. Grade 4
- BS4 Structural steel sections standard
- AS/NZS1891 Industrial fall-arrest systems and devices
- Pressure Equipment, Cranes and Passenger Ropeways Regulations 1999
- *Approved Code of Practice for Cranes*
- *Approved Code of Practice for Handling Precast Concrete*
- *Guidelines for Safety and Health in Port Operations*
- Maritime Rules Part 49, Ships' Lifting Appliances

(Visual inspection should be carried out prior to and during use at all times.)